



MANTION

WWW.MANTION-MANUTENTION.COM

MONORAILS

HANDHÄNGEBAHN



MONORAILS

821



Un nouveau regard sur la MANUTENTION AÉRIENNE

🇬🇧 A new glance at the manuel operated handling system

🇩🇪 Ein neuer Blick auf Handhängebahnsystem



🇫🇷 MANTION BÉNÉFICIE D'UNE NOTORIÉTÉ INTERNATIONALE QUI REPOSE SUR:

- L'innovation et l'adaptation permanente de ses produits aux besoins de ses clients.
- La qualité de ses produits respectant les normes les plus sévères du marché.

LE SAVOIR-FAIRE MANTION C'EST AVANT TOUT:

- Son équipe: des hommes et des femmes avec des compétences éprouvées, qui mettent tout en œuvre pour vous apporter, chaque jour, le meilleur service.
- Sa politique d'investissement permanent allié à l'utilisation des technologies les plus récentes.

AVEC MANTION, VOUS BÉNÉFICIEZ D'UN SERVICE DE TRÈS HAUTE QUALITÉ :

- Des technico-commerciaux à l'écoute de vos besoins.
- Une forte assistance technique: un bureau d'études et des conseillers techniques, chez vous à votre demande.
- L'étude et la réalisation de produits sur mesure.
- Des délais de livraison très rapides.
- Des produits de très haute qualité.

MANTION C'EST AUSSI UNE GAMME COMPLÈTE:

- Des ferrures de portes coulissantes et pliantes.
- Des ferrures de portes sectionnelles et battantes.
- Des ferrures de portes en verre.
- Des ferrures de portes en inox 304 L et 316 L.

MANTION, soucieux de vous apporter la meilleure prestation, tant au niveau de ses produits que de son organisation est certifié conforme aux exigences des normes:

ISO 9001
ISO 14001

🇬🇧 MANTION HAS AN INTERNATIONAL REPUTATION BASED ON:

- innovation and a permanent adaptation of its range of products to its customers' needs.
- a quality product, which responds to the requirements of the strictest standards.

THE MANTION KNOW-HOW MEANS BEFORE ALL:

- its team: people with experience and great skills who do their best to keep bringing you the best service.
- its permanent investment policy combined to the newest technologies.

WITH MANTION, YOU BENEFIT FROM A TOP QUALITY SERVICE:

- Salesmen who listen to your needs and advise you.
- A strong technical aid: an engineering department and technical advisers at your disposal.
- The study and the development of special products upon request.
- Very short delivery time.
- Very high quality products.

MANTION, THIS IS ALSO A COMPLETE RANGE:

- Fittings for sliding and folding doors.
- Fittings for sectional doors.
- Fittings for glass doors.
- Fittings in stainless steel quality A2 and A4.

Since MANTION has always cared about bringing you the best services within its organization and quality for its products, it is now up to standard:

ISO 9001
ISO 14001





 **MANTION PROFITIERT VON EINEM INTERNATIONALEN BEKANNTHEITSGRAD, DER SICH STÜTZT AUF:**

- Die Innovation und die permanente Anpassung seiner Produkte an die Bedürfnisse seiner Kunden.
- Die Qualität seiner Produkte und Einhaltung der strengsten Normen des Marktes.

DAS KNOW-HOW VON MANTION IST VOR ALLEM:

- Das Team: Männer und Frauen mit erprobter Kompetenz, die ihr Bestes tun, um Ihnen jeden Tag aufs Neue den besten Service bieten zu können.
- Die Investitionspolitik, immer verbunden mit der Anwendung neuester Technologien.

MIT MANTION PROFITIEREN SIE VON EINEM SERVICE MIT HÖCHSTER QUALITÄT:

- Die technischen Angestellten sind immer für Sie da.
- Eine starke technische Unterstützung:

ein Forschungsbüro und technische Experten, die auf Wunsch zu Ihnen kommen.

- Das Studieren und Realisieren der Produkte auf Maß.
- Kurze Lieferzeiten.
- Produkte von sehr hoher Qualität.

MANTION: DAS IST AUCH EIN KOMPLETTES SORTIMENT:

- Beschläge für Schiebetore und Harmonikatüren.
- Beschläge für Sektional- und Flügeltore.
- Beschläge für Glastüren.
- Beschläge für Türen aus Edelstahl VA2 304 L und VA4 316 L.

MANTION ist darauf bedacht, die beste Leistung für Sie zu bringen, sowohl bei seinen Produkten als auch bei der Organisation. Manton ist zertifiziert nach den Anforderungen der Norm :

ISO 9001

ISO 14001



MANTION ET SON LABORATOIRE D'ESSAI:

Mantion soucieux de la qualité de ses produits, dispose de l'un des plus grands centres d'essais d'Europe dans le domaine du couissant. En effet ce n'est pas moins de 5 bancs d'essai qui martyrisent à longueur d'année des systèmes couissants, afin d'éprouver leur endurance. Tous les systèmes Mantion sont soumis à ces essais préalables, le tout réalisé avec la rigueur de la norme ISO 9001.

MANTION AND ITS TEST LABORATORY:

Mantion, which always focuses on the quality of its products, has one of the biggest test laboratories for sliding systems in Europe. 5 test stands enable Mantion to assay the endurance of all its sliding systems in order to comply with the requirements of the ISO 9001 standard.

MANTION UND SEIN PRÜFSZENTER:

Mantion, dem die Qualität seiner Produkte sehr am Herzen liegt, verfügt über eines der größten Prüfszenter Europas auf dem Gebiet von Schiebesystemen. Tatsächlich «quälen» nicht weniger als 5 Prüfstände das ganze Jahr Schiebesysteme, um ihre Ausdauer zu prüfen. Alle Systeme von Mantion werden zuerst diesen Versuchen unterzogen, um den rauen Anforderungen der ISO 9001 gerecht zu werden.

Nos éléments standards permettent de réaliser aisément des installations personnalisées. La durée de vie des composants installés est variable selon ses conditions d'utilisation et de l'environnement dans lequel il se trouve. Dans tous les cas, elles doivent être déterminées par l'installateur. Celui-ci tiendra compte du fonctionnement, de l'espacement des supports, de la nature et du volume des charges transportées.

Nos articles sont garantis contre tout vice de fabrication, toutefois, cette garantie est limitée au remplacement des pièces défectueuses, à l'exclusion de tous dommages et intérêts, pour quelque cause que ce soit. Les pièces ayant subi une modification ou installées selon d'autres procédures (disponibles sur demande) que celles que nous recommandons ne bénéficierons pas de la garantie.

Our standard elements make possible to create easily personalized installations. The lifespan of the components installed is variable according to its environment and conditions of use. In all cases, they must be determined by the resaler. This one will take care of the running method, the spacing of the brackets, the nature and the volume of the transported loads.

Our products are warranted against manufacture fault, however, this warranty is limited to the replacement of the defective parts only and not for damages or consequential claims of any nature. Modified parts and material installed in a different way than the one we are recommended (recommandations available on demand) are not under warranty any more.

Unsere Standartelemente ermöglichen Konstruktionen, die Ihren persönlichen Wünschen entsprechen. Die Lebensdauer der Komponenten ist abhängig von Ihren Nutzungsbedingungen. Diese müssen von den Vertreter definiert werden. Er muss das Volumen, die Gewichte und die Aufhängungen berücksichtigen.

Unsere Produkte sind gewährleistet gegen Produktionsmängel. Die Gewährleistung ist jedoch begrenzt: Ersatz vom defekten Teilen, geänderte Teile und Material, Installationen nicht gemäß Mantion's Anweisung (zu Verfügung auf Anfrage) sind von der Gewährleistung ausgeschlossen.

Nos produits ne sont pas soumis à l'autocertification CE car ils sont vendus en tant que composants indépendants. Cela devient une machine lorsque ils sont montés sous une charpente par le constructeur. La certification CE doit alors être produite par le concepteur de l'installation.

Our product are not suitable for autocertification CE because they are sold as independant parts. They are becoming a machine when they are built up together linked with a steel construction. The CE certification have to be done by the installer.

Das Produkt entspricht erst der CE -Verordnung wenn es zusammengebaut ist. Die CE Zertifizierung erfolgt über den Hersteller, inklusive der Stahlbau Konstruktion.



Les diverses informations techniques présentes dans ce catalogue sont données à titre indicatif, vous ne pouvez pas utiliser telles que. Il convient de vérifier ces informations sur nos fiches techniques ou nous consulter afin d'avoir la bonne définition du matériel en fonction de vos implantations et charges.

Nos fiches techniques sont disponibles sur notre site internet ou bien sur demande.

The technical information in this catalogue is for information purposes only and cannot be used as is.

Information should be cross-checked with technical data sheets or directly with us to ensure equipment corresponds to your installation site and loads.

Our technical data sheets are available via our website or on request.

„Bei den verschiedenen, in diesem Katalog aufgeführten technischen Angaben handelt es sich um Richtwerte, die nicht unmittelbar übernommen werden dürfen.

Diese Angaben sollten anhand unserer technischen Datenblätter überprüft bzw. bei uns erfragt werden, um eine geeignete Ausstattung passend zur jeweiligen Einbausituation und Belastung festzulegen.

Unsere technischen Datenblätter sind auf unserer Internetseite bzw. auf Anfrage erhältlich.“



RAILS ET COURBES

TRACKS AND CURVES / SCHIENEN UND BÖGEN



- Rails / Tracks / Schienen 08
- Courbes / Curves / Bögen 09

AIGUILLAGES

SWITCHES / WEICHEN



- Commande aiguillage / Switch control / Weichenbetätigung 10
- Aiguillages à tiroir 2 voies / 2 ways sliding switches /
Schubladenweichen, 2-fach 13
- Aiguillages à tiroir 3 voies / 3 ways sliding switches /
Schubladenweichen, 3-fach 14
- Aiguillages à aiguille / Tongue switches / Zungenweichen..... 15
- Aiguillages et Plaques tournantes / Switches and turntables /
Weichen und Drehscheiben..... 20

FIXATIONS

HANGER / BEFESTIGUNGSMATERIAL



- Supports / Brackets / Muffe 24
- Jonctions de rails / Jointings Brackets / Befestigungen und Verbindungen 26
- Tirant / Threaded rod / Zuganker / 28
- Manchons de dilatation et rails escamotable / Expansion units and rail breakings /
Muffe gegen Schienenausdehnung und aushängbare Schiene 30

CHARIOTS

TROLLEYS / TRANSPORTWAGEN



- Chariots Armature / Trolleys / Transporthänger 32
- Anneaux ou Crochets / Rings or Hooks / Ring oder Haken..... 35
- Butée / Stoppers / Stopper 36
- Palonniers / Load bars / Traverse..... 37

LEVAGE ET AUTOMATISATION

LIFTING AND AUTOMATISATION / HEBEN UND AUTOMATISIERUNG



- Stations élévatrices / Drop sections / Absenkstationen 38
- Transfert latéral / Lateral transfer / Seitliche Mitnahme 40

INOX

STAINLESS STEEL / EDELSTAHL



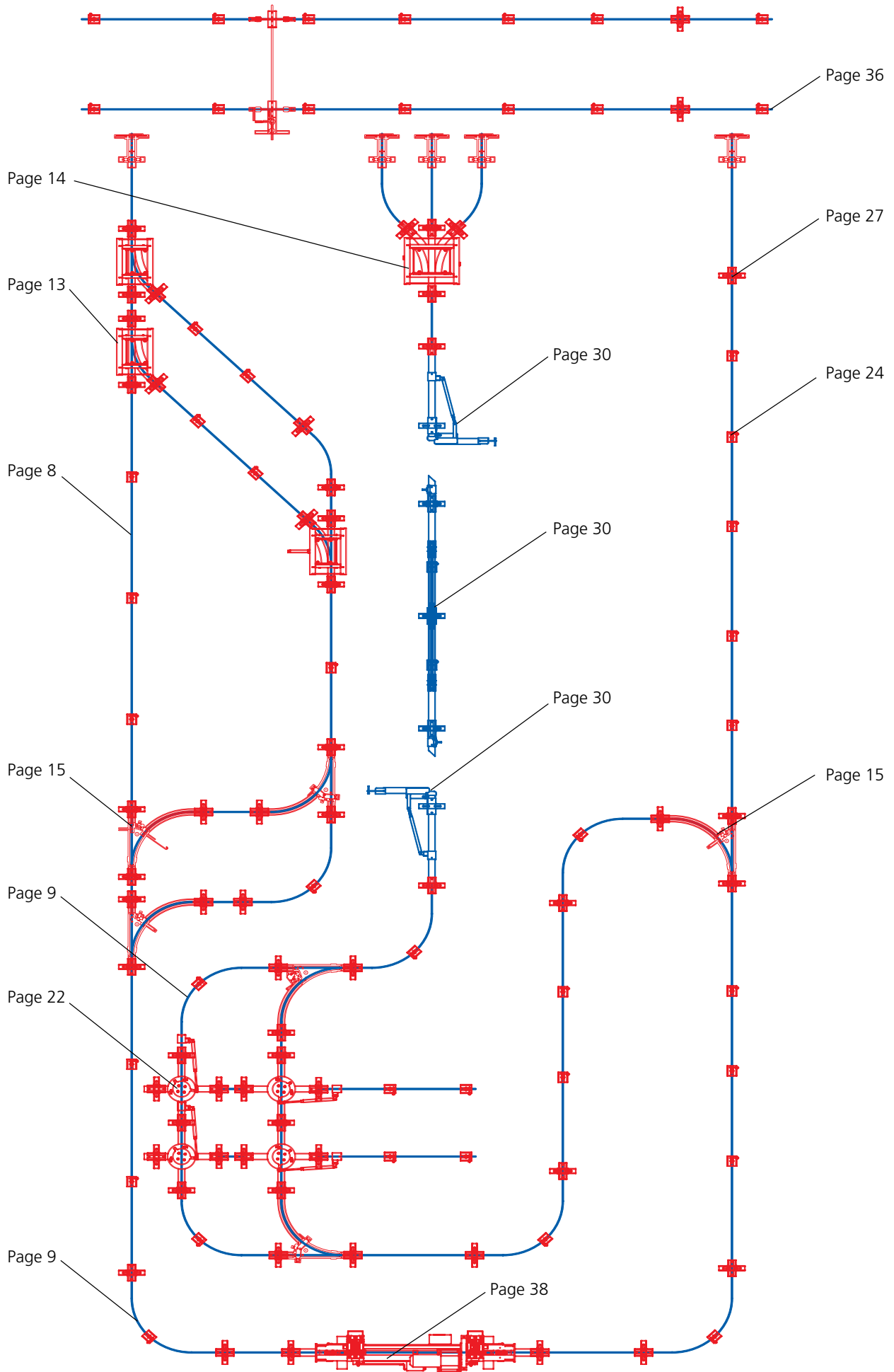

- Inox / Stainless steel / Edelstahl..... 44

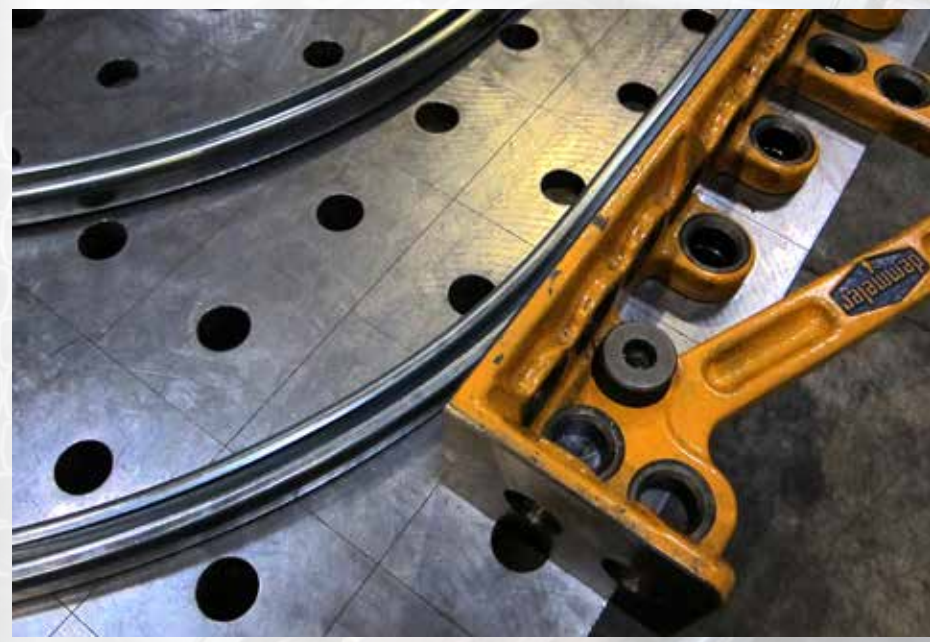
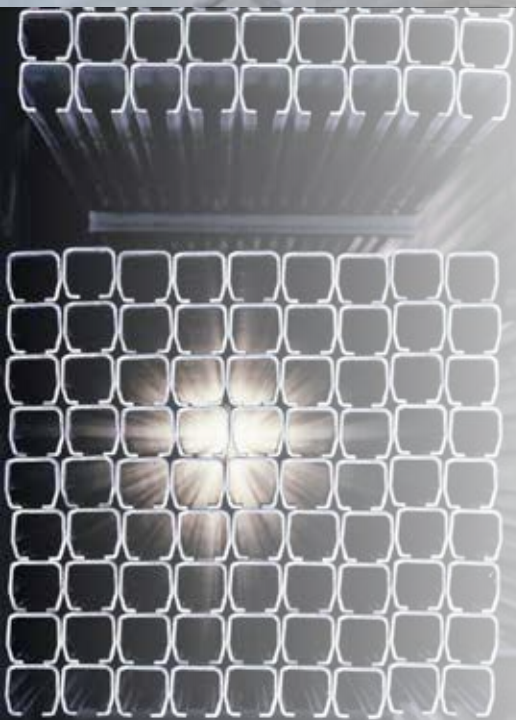

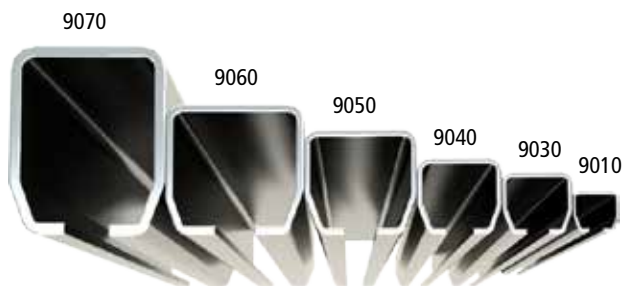
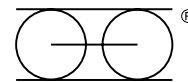



Les rails de notre fabrication portent le logo , c'est une garantie de qualité. IMPORTANT: les rails doivent être fixés de niveau grâce à nos supports spéciaux

The tracks manufactured by MANTION have their own logo , It is a guarantee of quality. IMPORTANT: Use our special brackets as the tubular profile must be level.

Schienen aus unserer Herstellung tragen das Logo . Dieses garantiert Qualität. WICHTIG: Die Schienen müssen mit unserem speziellen Befestigungsmaterial fixiert werden.

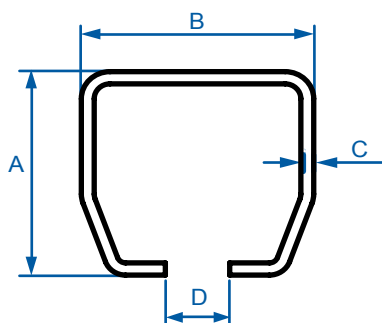

Ref	A	B	C	D
9010	28	30	1.8	10
9030	35	40	2.5	12
9040	43.5	48.5	3	15
9050	60	65	3.5	18
9060	75	80	4.5	22
9070	110	90	6	25

- Rails acier galvanisé lg std = 6 m
- Galvanised steel track length = 6 m
- Stahlschiene, galvanisch verzinkt, Standardlänge = 6 m

CHARGE UNITAIRE ENTRE 2 POINTS / Load between 2 points / Punktuelle Belastung zwischen 2 Punkten

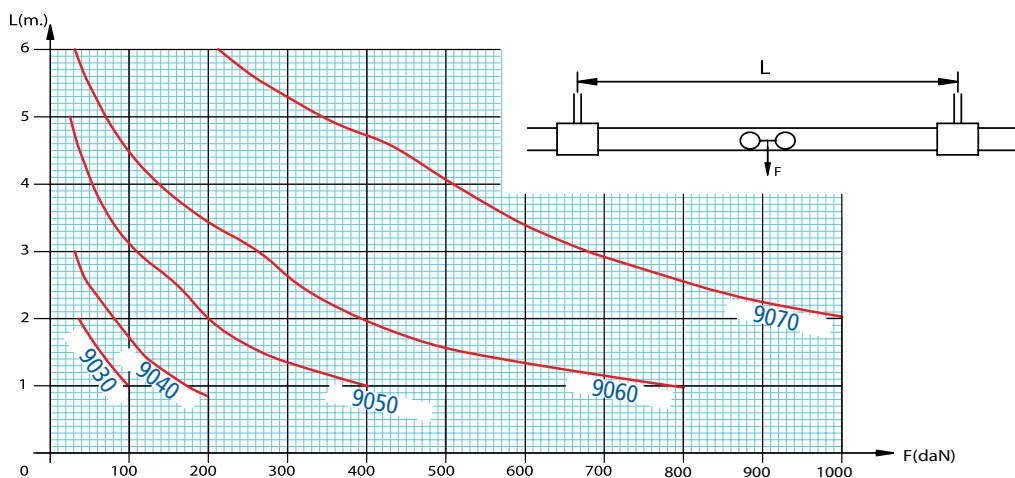

FLÈCHE MAXI = 1/300^{EME}
 max deflection = 1/300
 maxi = 1/300

CHARGE UNIFORMÉMENT RÉPARTIE / Load uniformly distributed / Belastung bei gleichmäßiger Verteilung

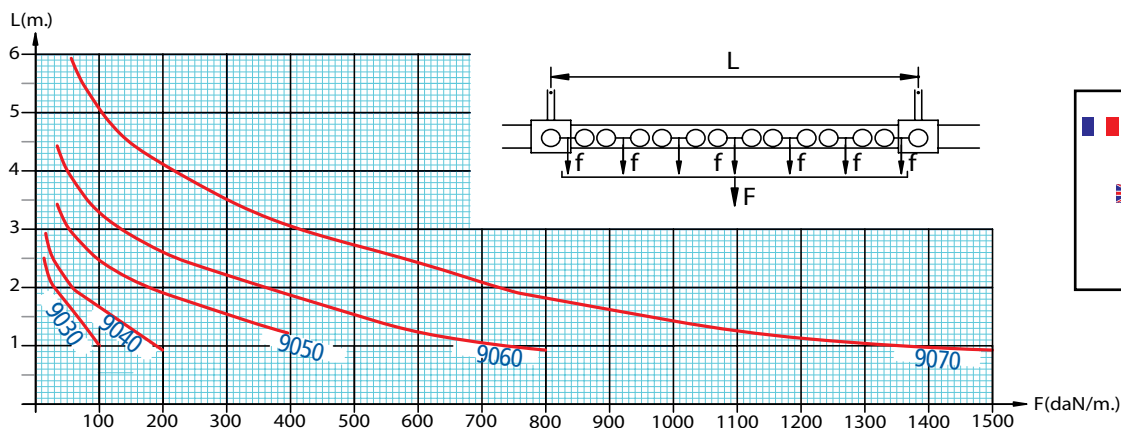

FLÈCHE MAXI = 1/300^{EME}
 max deflection = 1/300
 maxi = 1/300



COURBES HORIZONTALES

Horizontal Curves / Bogen horizontal

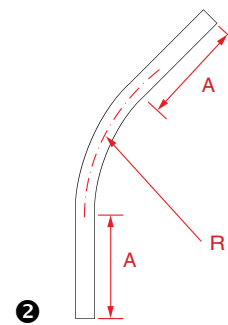
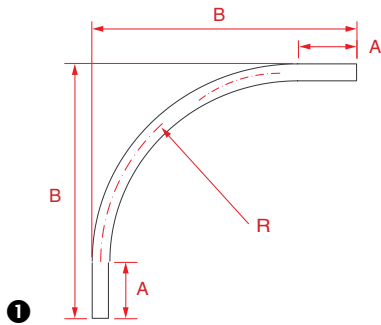

Ref	A	B	R
1 Courbes horizontales à 90° / Horizontal curves at 90° / Bogen 90°, horizontal			
9010C	360	875	500
9030C	430	1050	600
9040C	426	1050	600
9050C	350	982	600
9060C	350	1190	800
9070C	300	1345	1000
2 Courbes horizontales à 45° / Horizontal curves at 45° / Bogen 45°, horizontal			
9030C45	350	–	600
9040C45	350	–	600
9050C45	350	–	600
9060C45	350	–	800

COURBES VERTICALES

Vertical Curves / Bogen vertikal

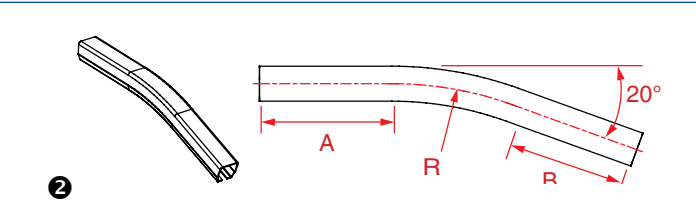
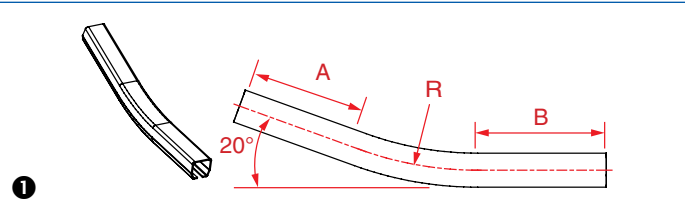

Ref	A	B	R
1 Courbes verticales à 20° / Vertical curves at 20° / Bogen 20°, vertikal			
9010CB	230	230	500
9030CB	205	205	600
9040CB	220	220	600
9050CB	225	225	600
9060CB	255	365	800
2 Courbes verticales à 20° / Vertical curves at 20° / Bogen 20°, vertikal			
9010CH	230	230	500
9030CH	205	205	600
9040CH	220	220	600
9050CH	225	225	600
9060CH	365	255	800



■ ■ DÉTERMINATION DU SENS DE L'AIGUILLAGE

🇬🇧 Determination of the direction of the switch / 🇩🇪 Bestimmung der Weichenrichtung

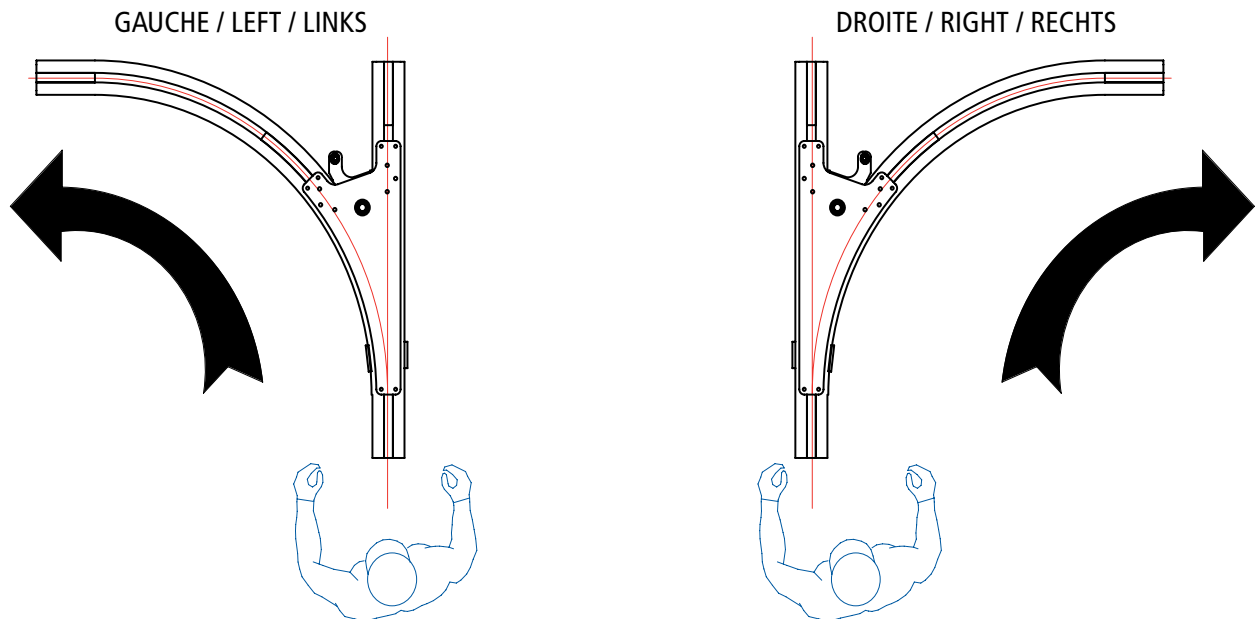

■ ■ Pour déterminer la direction d'un aiguillage, regarder l'élément concerné vu de dessus. Se placer devant le composant avant la bifurcation, si la courbe part à gauche, c'est un aiguillage à gauche, si la courbe part à droite, c'est un aiguillage à droite.

🇬🇧 To determine the direction of a switch, look the concerned element seen of the top. place itself in front of the component before the junction, if the curve leaves on the left, it is a left switch, if the curve leaves on the right, it is a right switch.

🇩🇪 Um die Richtung der Weiche zu bestimmen, muss diese von oben betrachtet werden. Vor der Gabelung stehend, sieht man so, in welche Richtung die Weiche abgeht.

■ ■ AIGUILLAGES À TIROIR 2 VOIES - REGROUPEMENT AUTOMATIQUE

🇬🇧 2 ways sliding switches - Automatic regrouping

🇩🇪 Schubladenweiche, 2-fach, - Automatisch zusammenführend

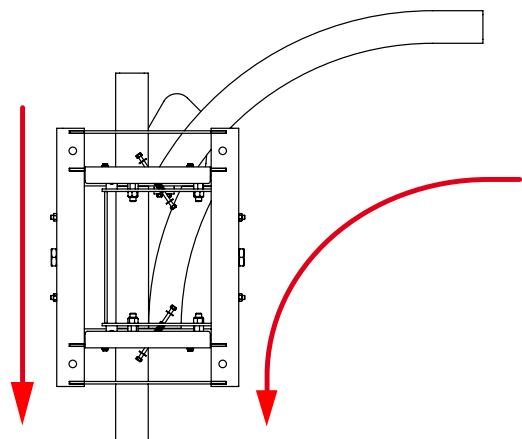

■ ■ Aiguillage automatique regroupement . Permet de joindre deux lignes de monorail en une seule.

Le tiroir de l'aiguillage est déplacé par le chariot avant que ce dernier ne commence à rouler dessus. Cela permet au tiroir de se mettre en place et de se verrouiller en position. Cette opération est entièrement automatique et ne nécessite pas d'intervention manuelle.

🇬🇧 Automatic regrouping switch. Allows you to join two monorail lines into one.

The drawer of the switch is moved by the trolley before it starts to roll on it. This allows the drawer to set up and lock into position. This operation is fully automatic and does not require manual intervention.

🇩🇪 Automatische zusammenführende Weichen stellen sich automatisch ein. Kein manueller Einsatz notwendig. Sie sind nur in einer Richtung einsatzfähig.

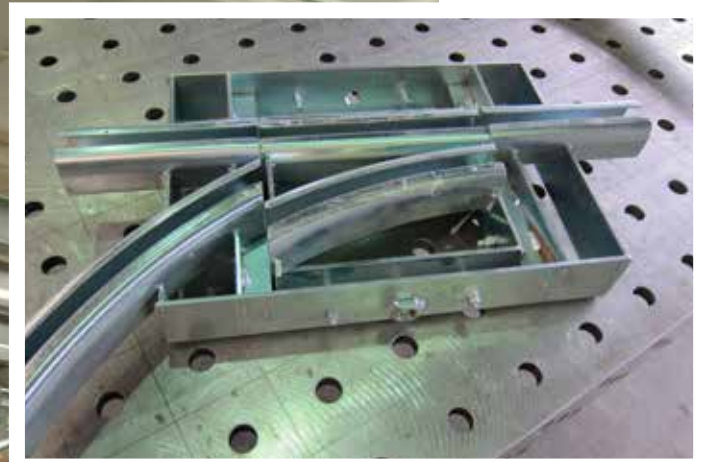



■ ■ COMMANDE AIGUILLAGES À TIROIR

🇬🇧 Switch control / 🇩🇪 Weichenbetätigung

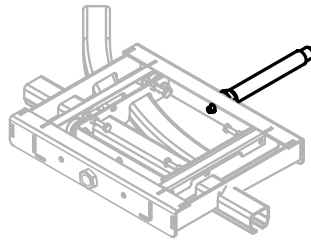
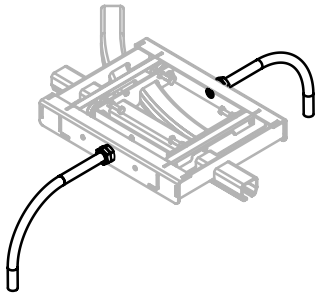

ref

CM

■ ■ Commande d'aiguillage **manuelle**.
Tube de commande manuelle à visser sur châssis. Chaînette non fournie.

🇬🇧 **Manual** switch control
Srew hand drive pipes on switch. Chain not provided.

🇩🇪 Weichenbetätigung **Manuell**:
Manuelles Betätigungsgestänge, anzuschrauben am Rahmen.
Optional mit Kette.

ref

CP

■ ■ Commande d'aiguillage **pneumatique**.
Montage possible du vérin à droite ou à gauche,
Raccords sur vérins double effet = 1/8F. Distributeur pneumatique non fourni.

🇬🇧 **Pneumatic** switch control
Pneumatic jack assembly is possible on the right or on the left
Connections on double-acting jack = 1/8F not supplied

🇩🇪 Weichenbetätigung **pneumatisch**:
Kann anhand des Gewindes sowohl rechts als auch links befestigt werden.
Verbindungsstück auf doppeltem Winde-effekt = 1/8F pneumatisches Ventil nicht

■ ■ KIT CHÂÎNE DE MANOEUVRE

🇬🇧 Chain kit for manual operating / 🇩🇪 Weichenbetätigung



ref

9000CDE1

■ ■ Kit chaîne de manoeuvre simple pour commande manuelle.
1 chaînette avec boule de manoeuvre pour la manipulation des **aiguillages à tiroirs 3 voies et indexations**. Ce kit comprend 1 chaînette de longueur 4 m. avec boule.

🇬🇧 Single chain kit for manual operating
Chain with a ball for **3 ways sliding switches and lockings**. This kit includes a chain of 4 m. with ball

🇩🇪 1 Kette (4M Lang) mit Kugel für **3Fach-Schubladenweichenbetätigung und Verriegelungen**.

ref

9000CDE2

■ ■ Kit chaînes de manoeuvre double pour commande manuelle.
2 chaînettes avec boule de manoeuvre pour la manipulation des **aiguillages à tiroirs**. Ce kit comprend 2 chaînettes de longueur 4 m. avec boule.

🇬🇧 Dual chain kit for manual operating
Two chains with balls maneuver for **sliding switches**. This kit includes 2 chains of 4 m. with balls.

🇩🇪 2 Kette (4M Lang) mit Kugel für **Schubladenweichenbetätigung**.

ref

9000CDEA

■ ■ Kit câbles de manoeuvre double pour commande manuelle.
2 câbles avec boule de manoeuvre pour la manipulation des **aiguillages à aiguille**. Ce kit comprend 2 câbles de longueur 4 m. avec boule.

🇬🇧 Dual Cable kit for manual operating
Two cable with balls maneuver for **tongue switches**. This kit includes 2 cable of 4 m. with balls.

🇩🇪 2 Kabel (4M Lang) mit Kugel für **Zungenweichenbetätigung**.

■ ■ AIGUILLAGES À TIROIR 2 VOIES À 90°

2 ways sliding switches AT 90°
 Schubladenweiche, 2-fach, 90°

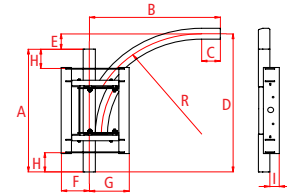

□	A	B	C	D	E	F	G	H	I	R
9030	580	700	100	770	190	123	193	83	27	600
9040	580	700	100	770	190	139	192	83	27	600
9050	735	700	100	827	92	150	213	110	50	600
9060	810	910	110	1027	217	166	248	115	56	800

Désignation / Description / Beschreibung		□	gauche/left/links	droite/right/rechts
<p> ■ ■ Aiguillage à commande manuelle ou pneumatique, commande à choisir p.12 Manual or Pneumatic switch, control Control to choose on p.12 Weichen Manuell oder pneumatisch, Betätigung zu wählen S.12 </p>	9030	9301GCS	9301DCS	
	9040	9401GCS	9401DCS	
	9050	9501GCS	9501DCS	
	9060	9601GCS	9601DCS	
<p> ■ ■ Automatique regroupement (voir p.10) Automatic regrouping (see on p.10) Automatisch zusammenführend (siehe S.10) </p>	9030	9301GCSAR	9301DCSAR	
	9040	9401GCSAR	9401DCSAR	
	9050	9501GCSAR	9501DCSAR	
	9060	9601GCSAR	9601DCSAR	

■ ■ AIGUILLAGES À TIROIR 2 VOIES À 45°

2 ways sliding switches AT 45°
 Schubladenweiche, 2-fach, 45°

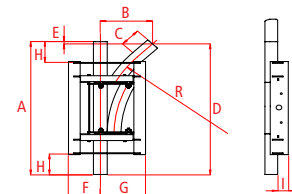

□	A	B	C	D	E	F	G	H	I	R
9030	580	246	100	665	85	123	193	83	27	600
9040	580	246	100	665	85	139	192	83	27	600
9050	735	246	100	722	13	150	213	110	50	600
9060	810	312	110	870	60	166	248	115	56	800







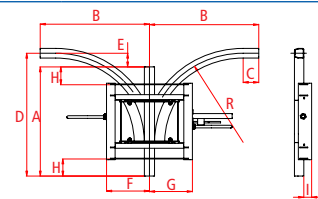

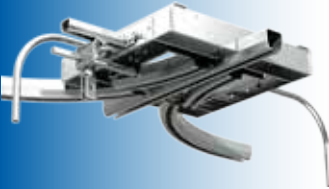

Désignation / Description / Beschreibung		□	gauche/left/links	droite/right/rechts
<p> ■ ■ Aiguillage à commande manuelle ou pneumatique, commande à choisir p.12 Manual or Pneumatic switch, control Control to choose on p.12 Weichen Manuell oder pneumatisch, Betätigung zu wählen S.12 </p>	9030	9301GS	9301DS	
	9040	9401GS	9401DS	
	9050	9501GS	9501DS	
	9060	9601GS	9601DS	
<p> ■ ■ Automatique regroupement (voir p.10) Automatic regrouping (see on p.10) Automatisch zusammenführend (siehe S.10) </p>	9030	9301GSAR	9301DSAR	
	9040	9401GSAR	9401DSAR	
	9050	9501GSAR	9501DSAR	
	9060	9601GSAR	9601DSAR	

AIGUILLAGES À TIROIR 3 VOIES À 90°

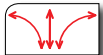

 **3 ways sliding switches at 90°**
 **Schubladenweiche, 3-fach, 90°**



	A	B	C	D	E	F	G	H	I	R
9030	644	700	100	802	158	223	223	115	27	600
9040	624	700	100	792	168	239	239	105	27	600
9050	735	700	100	827	92	275	275	115	50	600
9060	860	910	110	1052	192	331	331	140	56	800







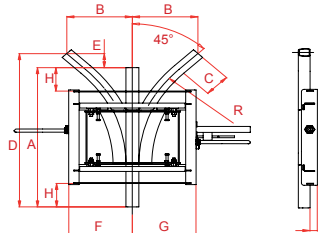

Désignation / Description / Beschreibung			ref
 <p> Aiguillages à tiroir 3 voies à 90° manuel Kits de chaîne à choisir page 12  Manual 3 ways sliding switches at 90° Chain kit to choose on p.12  Manuelle Schubladenweiche, 3-fach, 90° Weichenbetätigung zu wählen S.12</p> 		9030	9303CSM
		9040	9403CSM
		9050	9503CSM
		9060	9603CSM
 <p> Aiguillages à tiroir 3 voies à 90° pneumatique (verin fourni) Distributeur pneumatique non fourni  Pneumatic 3 ways sliding switches at 90° (jack provided) Pneumatic valve not provided  Pneumatisch Schubladenweiche, 3-fach, 90° (Winde enthalten) Pneumatische Betätigung nicht enthalten</p> 		9030	9303CSP
		9040	9403CSP
		9050	9503CSP
		9060	9603CSP

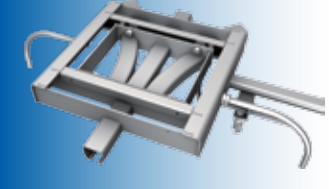
AIGUILLAGES À TIROIR 3 VOIES À 45°

 **Manual 3 ways sliding switches at 45°**
 **Schubladenweiche, 3-fach, 45°**

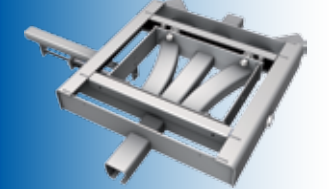

	A	B	C	D	E	F	G	H	I	R
9030	644	246	100	697	53	223	223	115	27	600
9040	624	246	100	687	63	239	239	105	27	600
9050	735	246	100	722	13	275	275	115	50	600
9060	860	312	110	895	35	331	331	140	56	800

Désignation / Description / Beschreibung			ref
 <p> Aiguillages à tiroir 3 voies à 45° manuel Kits de chaîne à choisir page 12  Manual 3 ways sliding switches at 45° Chain kit to choose on p.12  Manuelle Schubladenweiche, 3-fach, 45° Weichenbetätigung zu wählen S.12</p> 		9030	9303SM
		9040	9403SM
		9050	9503SM
		9060	9603SM
 <p> Aiguillages à tiroir 3 voies à 45° pneumatique (verin fourni) Distributeur pneumatique non fourni  Pneumatic 3 ways sliding switches at 45° (jack provided) Pneumatic valve not provided  Pneumatisch Schubladenweiche, 3-fach, 45° (Winde enthalten) Pneumatische Betätigung nicht enthalten</p> 		9030	9303SP
		9040	9403SP
		9050	9503SP
		9060	9603SP

■ ■ AIGUILLAGES À AIGUILLE À 90°

Tongue switches at 90°
 Zungenweiche, 90°

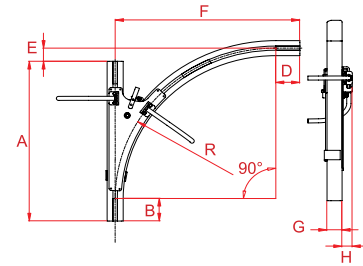

□	A	B	C	D	E	F	G	H
9040	710	120	600	120	10	720	43.5	32
9050	750	120	600	120	30	720	60	50
9060	850	120	800	120	70	920	75	51

Désignation / Description / Beschreibung		□	gauche/left/links	droite/right/rechts
<p> ■ ■ Aiguillages à aiguille à 90° manuel Manual tongue switches at 90° Zungenweiche, 90°, Manuell </p>	9040	9401AIMCG	9401AIMCD	
	9050	9501AIMCG	9501AIMCD	
	9060	9601AIMCG	9601AIMCD	
<p> ■ ■ Aiguillages à aiguille à 90° pneumatique Pneumatic tongue switches at 90° Zungenweiche, 90°, Pneumatisch </p>	9040	9401AIPCG	9401AIPCD	
	9050	9501AIPCG	9501AIPCD	
	9060	9601AIPCG	9601AIPCD	
<p> ■ ■ Aiguillages à aiguille à 90° automatique regroupement Automatic regrouping tongue switch at 90° Zungenweiche, 90°, Automatisch zusammenführend </p>	9040	9401AIARCG	9401AIARCD	
	9050	9501AIARCG	9501AIARCD	
	9060	9601AIARCG	9601AIARCD	
<p> ■ ■ Aiguillages à aiguille à 90° automatique palonniers Automatic tongue switch at 90° for load bars Zungenweiche auf Bogen, 90°, Automatisch wechselnd </p>	9040	9401AIAPCG	9401AIAPCD	
	9050	9501AIAPCG	9501AIAPCD	
	9060	9601AIAPCG	9601AIAPCD	

- Tube de commande manuelle à visser sur châssis. Câbles de manoeuvre non fournis mais disponibles page 12.
 Screw hand driven pipes on switch. Chain not provided but available on page 12.
 Manuelle Betätigungsgestänge, anzuschrauben am Rahmen. Kette nicht enthalten, Betätigung zu wählen S.12.
- Raccords sur vérins double effet = 1/8F, distributeur pneumatique non fourni.
 Connections on double-acting jack = 1/8F. Pneumatic valve not provided.
 Verbindungsstück auf doppeltem Windeffekt = 1/8F pneumatische Betätigung nicht enthalten.
- Cet aiguillage permet de regrouper deux lignes de monorail en une seule, cette opération est entièrement automatique et ne nécessite pas d'intervention manuelle.
 This switch gathers two lines of monorail in only one, this operation is entirely automatic and does not require any manual intervention.
 Diese Weiche ermöglicht das Zusammenschließen zweier Schienen zu einer. Dieses geschieht vollständig automatisch, ein manuelles Eingreifen ist nicht notwendig.
- Aiguillage prévu pour dégroupement automatique pour palonniers, le premier chariot va tout droit et le second prend la direction de la courbe. La remise en position initiale pour le palonnier suivant est automatique.
 Switch for automatic dispersal for load bars, the first trolley goes straight and the second takes the direction of the curve. The tongue comes back in initial position automatically.
 Weiche zur automatischen Gabelung. Der erste Transporthänger läuft geradeaus, der zweite nimmt die Richtung des Bogens. Die Anfangsposition des Bogens wird automatisch wieder eingenommen.



Avec les aiguillages à aiguille (toutes versions) n'utiliser que des chariots à guidage latéral. Version GL, GLHT, GLR ou GLRHT

With tongue Switches (all versions) use only trolleys with lateral guidance. GL version, GLHT, or GLR, GLRHT

ACHTUNG
 Die Zungenweichen sind in Kombination mit Laufwagen GL, GLHT, GLR, GLRHT zu verwenden.



■ ■ AIGUILLAGES À AIGUILLE À 45°

Tongue switches at 45°
 Zungenweiche, 45°

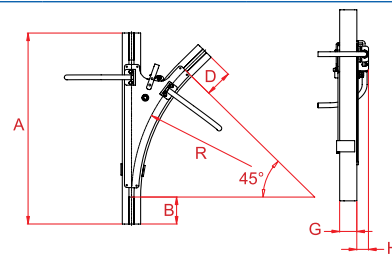

	A	B	C	D	E	F	G	H
9040	710	120	600	120	–	–	43.5	32
9050	750	120	600	120	–	–	60	50
9060	850	120	800	120	–	–	75	51

Désignation / Description / Beschreibung			gauche/left/links	droite/right/rechts
1	■ ■ Aiguillages à aiguille à 45° manuel Manual tongue switches at 45° Zungenweiche, 45°, Manuell 	9040	9401AIMG	9401AIMD
		9050	9501AIMG	9501AIMD
		9060	9601AIMG	9601AIMD
2	■ ■ Aiguillages à aiguille à 45° pneumatique Pneumatic tongue switches at 45° Zungenweiche, 45°, Pneumatisch 	9040	9401AIPG	9401AIPD
		9050	9501AIPG	9501AIPD
		9060	9601AIPG	9601AIPD
3	■ ■ Aiguillages à aiguille à 45° automatique regroupement Automatic regrouping tongue switch at 45° Zungenweiche, 45°, Automatisch zusammenführend 	9040	9401AIARG	9401AIARD
		9050	9501AIARG	9501AIARD
		9060	9601AIARG	9601AIARD
4	■ ■ Aiguillages à aiguille à 45° automatique palonniers Automatic tongue switch at 45° for load bars Zungenweiche auf Bogen, 45°, Automatisch wechselnd 	9040	9401AIAPG	9401AIAPD
		9050	9501AIAPG	9501AIAPD
		9060	9601AIAPG	9601AIAPD

- ■ Tube de commande manuelle à visser sur châssis. Câbles de manoeuvre non fournis mais disponibles page 12.**
 Screw hand driven pipes on switch. Chain not provided but available on page 12.
 Manuelle Betätigungsgestänge, anzuschrauben am Rahmen. Kette nicht enthalten, Betätigung zu wählen S.12.
- ■ Raccords sur vérins double effet = 1/8F, distributeur pneumatique non fourni.**
 Connections on double-acting jack = 1/8F. Pneumatic valve not provided.
 Verbindungsstück auf doppeltem Windeffekt = 1/8F pneumatische Betätigung nicht enthalten.
- ■ Cet aiguillage permet de regrouper deux lignes de monorail en une seule, cette opération est entièrement automatique et ne nécessite pas d'intervention manuelle.**
 This switch gathers two lines of monorail in only one, this operation is entirely automatic and does not require any manual intervention.
 Diese Weiche ermöglicht das Zusammenschließen zweier Schienen zu einer. Dieses geschieht vollständig automatisch, ein manuelles Eingreifen ist nicht notwendig.
- ■ Aiguillage prévu pour dégroupement automatique pour palonniers, le premier chariot va tout droit et le second prend la direction de la courbe. La remise en position initiale pour le palonnier suivant est automatique.**
 Switch for automatic dispersal for load bars, the first trolley goes straight and the second takes the direction of the curve. The tongue comes back in initial position automatically.
 Weiche zur automatischen Gabelung. Der erste Transporthänger läuft geradeaus, der zweite nimmt die Richtung des Bogens. Die Anfangsposition des Bogens wird automatisch wieder eingenommen.



■ ■ Avec les aiguillages à aiguille (toutes versions) n'utiliser que des chariots à guidage latéral. Version GL, GLHT, GLR ou GLRHT

■ ■ With tongue Switches (all versions) use only trolleys with lateral guidance. GL version, GLHT, or GLR, GLRHT

■ ■ ACHTUNG
 Die Zungenweichen sind in Kombination mit Laufwagen GL, GLHT, GLR, GLRHT zu verwenden.

■ ■ AIGUILLAGES À AIGUILLE EN Y À 90°

Y Zungenweiche, 90°/
 y tongue switches at 90°

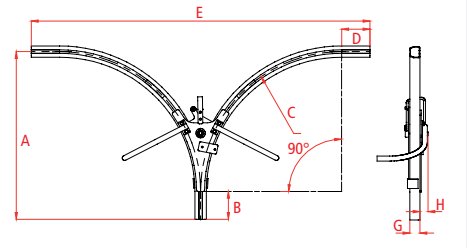

□	A	B	C	D	E	F	G	H
9040	720	120	600	120	1440	–	43.5	32
9050	720	120	600	120	1440	–	60	50
9060	920	120	800	120	1440	–	75	51

Désignation / Description / Beschreibung		□	Ref
 1	■ ■ Aiguillages à aiguille en Y à 90° manuel ■ ■ Manual Y tongue switches at 90° ■ ■ Y Zungenweiche, 90°, Manuell 	9040	9401AIYMC
		9050	9501AIYMC
		9060	9601AIYMC
 2	■ ■ Aiguillages à aiguille en Y à 90° pneumatique ■ ■ Pneumatic Y tongue switches at 90° ■ ■ Y Zungenweiche, 90°, Pneumatisch 	9040	9401AIYPC
		9050	9501AIYPC
		9060	9601AIYPC
 3	■ ■ Aiguillages à aiguille en Y à 90° automatique regroupement ■ ■ Automatic regrouping Y tongue switch at 90° ■ ■ Y Zungenweiche, 90°, Automatisch zusammenführend 	9040	9401AIYARC
		9050	9501AIYARC
		9060	9601AIYARC



- 1** ■ ■ Tube de commande manuelle à visser sur châssis. Câbles de manoeuvre non fournis mais disponibles page 12.
 Screw hand driven pipes on switch. Chain not provided but available on page 12.
 Manuelle Betätigungsgestänge, anzuschrauben am Rahmen. Kette nicht enthalten. Betätigung zu wählen S.12.
- 2** ■ ■ Raccords sur vérins double effet = 1/8F, distributeur pneumatique non fourni.
 Connections on double-acting jack = 1/8F. Pneumatic valve not provided.
 Verbindungsstück auf doppeltem Windeffekt = 1/8F pneumatische Betätigung nicht enthalten.
- 3** ■ ■ Cet aiguillage permet de regrouper deux lignes de monorail en une seule, cette opération est entièrement automatique et ne nécessite pas d'intervention manuelle.
 This switch gathers two lines of monorail in only one, this operation is entirely automatic and does not require any manual intervention.
 Diese Weiche ermöglicht das Zusammenschließen zweier Schienen zu einer. Dieses geschieht vollständig automatisch, ein manuelles Eingreifen ist nicht notwendig.



■ ■ Avec les aiguillages à aiguille (toutes versions) n'utiliser que des chariots à guidage latéral. Version GL, GLHT, GLR ou GLRHT

With tongue Switches (all versions) use only trolleys with lateral guidance. GL version, GLHT, or GLR, GLRHT

ACHTUNG
 Die Zungenweichen sind in Kombination mit Laufwagen GL, GLHT, GLR, GLRHT zu verwenden.







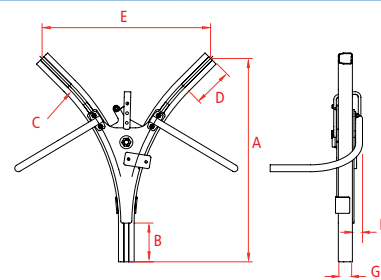

■ ■ AIGUILLAGES À AIGUILLE EN Y À 45°

Y tongue switches at 45°

Y Zungenweiche, 45°



□	A	B	C	D	E	F	G	H
9040	629	120	600	120	521	–	43.5	32
9050	629	120	600	120	521	–	60	50
9060	770	120	800	120	638	–	75	51

Désignation / Description / Beschreibung		□	Ref
1 	■ ■ Aiguillages à aiguille en Y à 45° manuel Manual Y tongue switches at 45° Y Zungenweiche, 45°, Manuell 	9040	9401AIYM
		9050	9501AIYM
		9060	9601AIYM
2 	■ ■ Aiguillages à aiguille en Y à 45° pneumatique Pneumatic Y tongue switches at 45° Y Zungenweiche, 45°, Pneumatisch 	9040	9401AIYP
		9050	9501AIYP
		9060	9601AIYP
3 	■ ■ Aiguillages à aiguille en Y à 45° automatique regroupement Automatic regrouping Y tongue switch at 45° Y Zungenweiche, 45°, Automatisch zusammenführend 	9040	9401AIYAR
		9050	9501AIYAR
		9060	9601AIYAR

1 ■ ■ Tube de commande manuelle à visser sur châssis. Câbles de manoeuvre non fournis mais disponibles page 12.

Screw hand driven pipes on switch. Chain not provided but available on page 12.

Manuelles Betätigungsgestänge, anzuschrauben am Rahmen. Kette nicht enthalten., Betätigung zu wählen S.12.

2 ■ ■ Raccords sur vérins double effet = 1/8F, distributeur pneumatique non fourni.

Connections on double-acting jack = 1/8F. Pneumatic valve not provided.

Verbindungsstück auf doppeltem Windeeffekt = 1/8F pneumatische Betätigung nicht enthalten.

3 ■ ■ Cet aiguillage permet de regrouper deux lignes de monorail en une seule, cette opération est entièrement automatique et ne nécessite pas d'intervention manuelle.

This switch gathers two lines of monorail in only one, this operation is entirely automatic and does not require any manual intervention.

Diese Weiche ermöglicht das Zusammenschließen zweier Schienen zu einer. Dieses geschieht vollständig automatisch, ein manuelles Eingreifen ist nicht notwendig.



■ ■ Avec les aiguillages à aiguille (toutes versions) n'utiliser que des chariots à guidage latéral. Version GL, GLHT, GLR ou GLRHT

With tongue Switches (all versions) use only trolleys with lateral guidance. GL version, GLHT, or GLR, GLRHT

ACHTUNG
 Die Zungenweichen sind in Kombination mit Laufwagen GL, GLHT, GLR, GLRHT zu verwenden.

■ ■ AIGUILLAGES À AIGUILLE EN T MANUEL

🇬🇧 Manual T tongue switches / 🇩🇪 T Zungenweiche, manuell

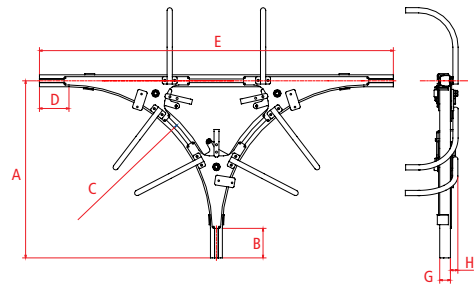
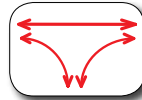
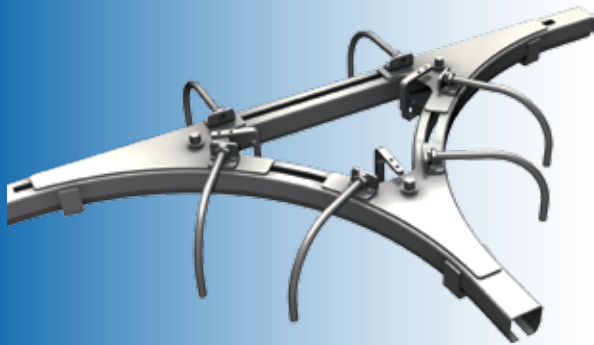

□	ref	A	B	C	D	E	G	H
9040	9401AITM	720	120	600	120	1440	43.5	32
9050	9501AITM	720	120	600	120	1440	60	50
9060	9501AITM	920	120	800	120	1840	75	51

■ ■ Tube de commande manuelle à visser sur châssis. Câbles de manoeuvre non fourni mais disponibles page 12.

🇬🇧 Screw hand driven pipes on switch. Chain not provided but available on pag 12.

🇩🇪 Manuelle Betätigungsgestänge, anzuschrauben am Rahmen. Kette nicht enthalten, Betätigung zu wählen S.12.

■ ■ AIGUILLAGES À AIGUILLE EN T PNEUMATIQUE

🇬🇧 Pneumatic T tongue switches / 🇩🇪 T Zungenweiche, pneumatisch

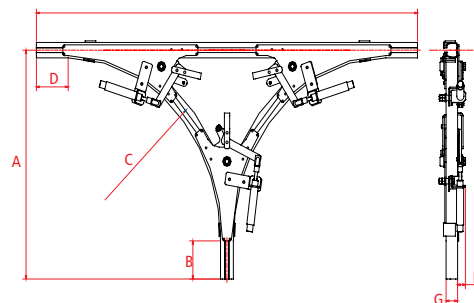
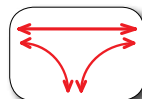

□	ref	A	B	C	D	G	H
9040	9401AITP	629	120	600	120	43.5	32
9050	9501AITP	629	120	600	120	60	50
9060	9601AITP	770	120	800	120	75	51

■ ■ Raccords sur vérins double effet = 1/8F, distributeur pneumatique non fourni.

🇬🇧 Connections on double-acting jack = 1/8F. Pneumatic valve not provided. Pneumatic valve not provided.

🇩🇪 Verbindungsstück auf doppeltem Windeeffekt = 1/8F pneumatische Betätigung nicht enthalten



■ ■ Avec les aiguillages à aiguille (toutes versions) n'utiliser que des chariots à guidage latéral. Version GL, GLHT, GLR ou GLRHT

🇬🇧 With tongue Switches (all versions) use only trolleys with lateral guidance. GL version, GLHT, or GLR, GLRHT

🇩🇪 **ACHTUNG**
Die Zungenweichen sind in Kombination mit Laufwagen GL, GLHT, GLR, GLRHT zu verwenden.



■ ■ AIGUILLAGES AUTOMATIQUES

 Automatic switches /  Automatisch Weiche

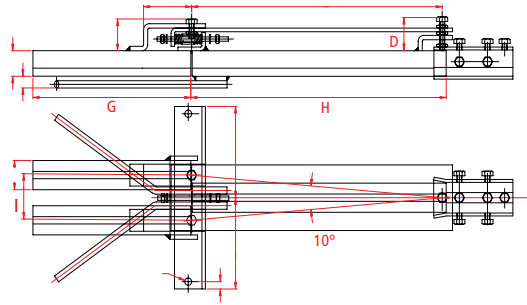
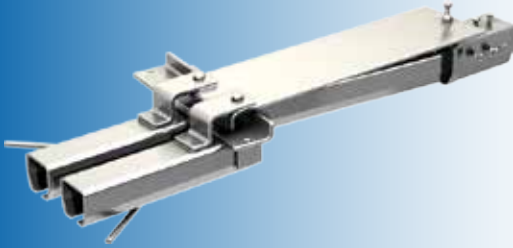

	ref	D	G	H	I
9010	9100A	55	230	370	62
9030	9300A	55	230	370	62
9040	9400A	55	230	370	62
9050	9500A	60	300	500	100
9060	9600A	60	300	500	100

■ ■ PLAQUES TOURNANTES

 Turntables /  Drehscheiben

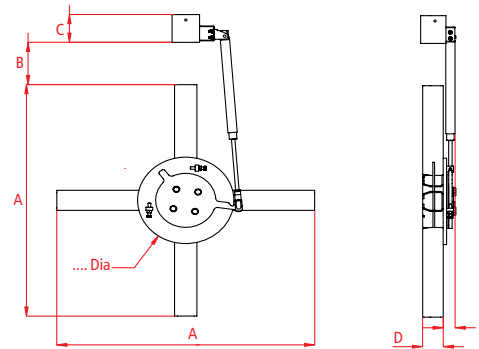
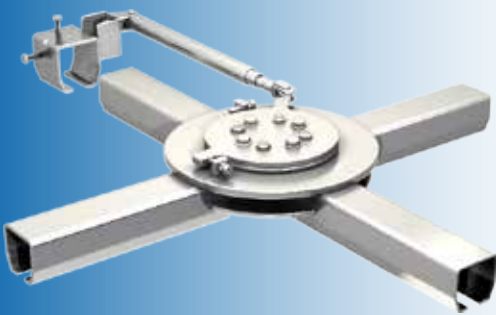

	ref	A	B	C	D	E	Dia
9030	9301P4	662	162	54	35	31	280
9040	9401P4	662	162	65	43.5	31	280
9050	9501P4	750	114	90	60	37	280
9060	9601P4	750	114	110	75	37	280

■ ■ Raccords sur vérins double effet = 1/8F, distributeur pneumatique non fourni.

 Connections on double-acting jack = 1/8F. Pneumatic valve not provided.



 Verbindungsstück auf doppeltem Windeffekt = 1/8F pneumatische Betätigung nicht enthalten.









AIGUILLAGES TOURNANTS

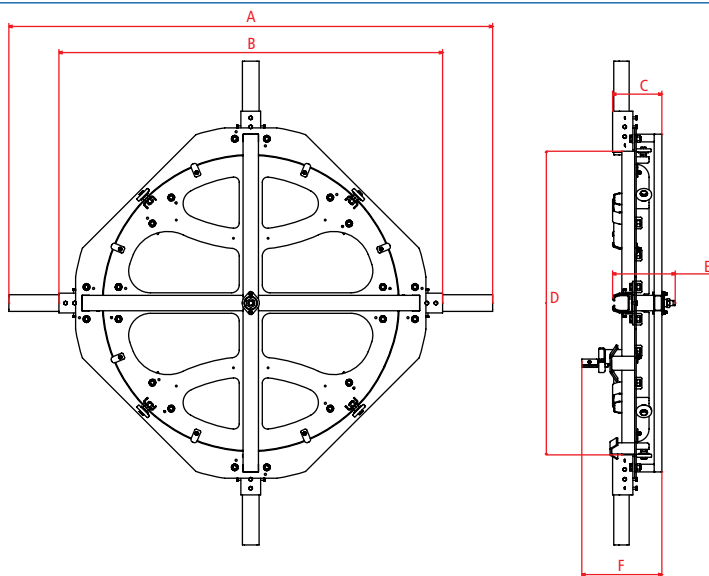
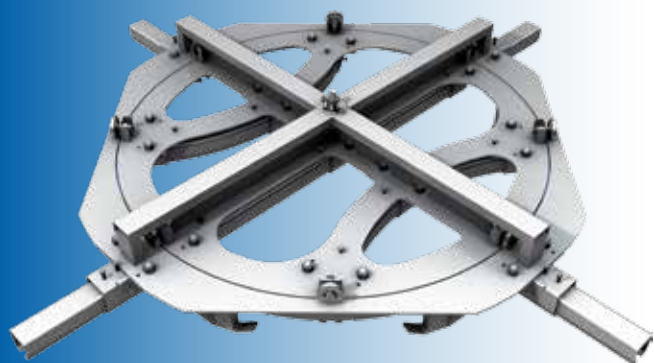

 Turning switches
 Drehscheibenweichen



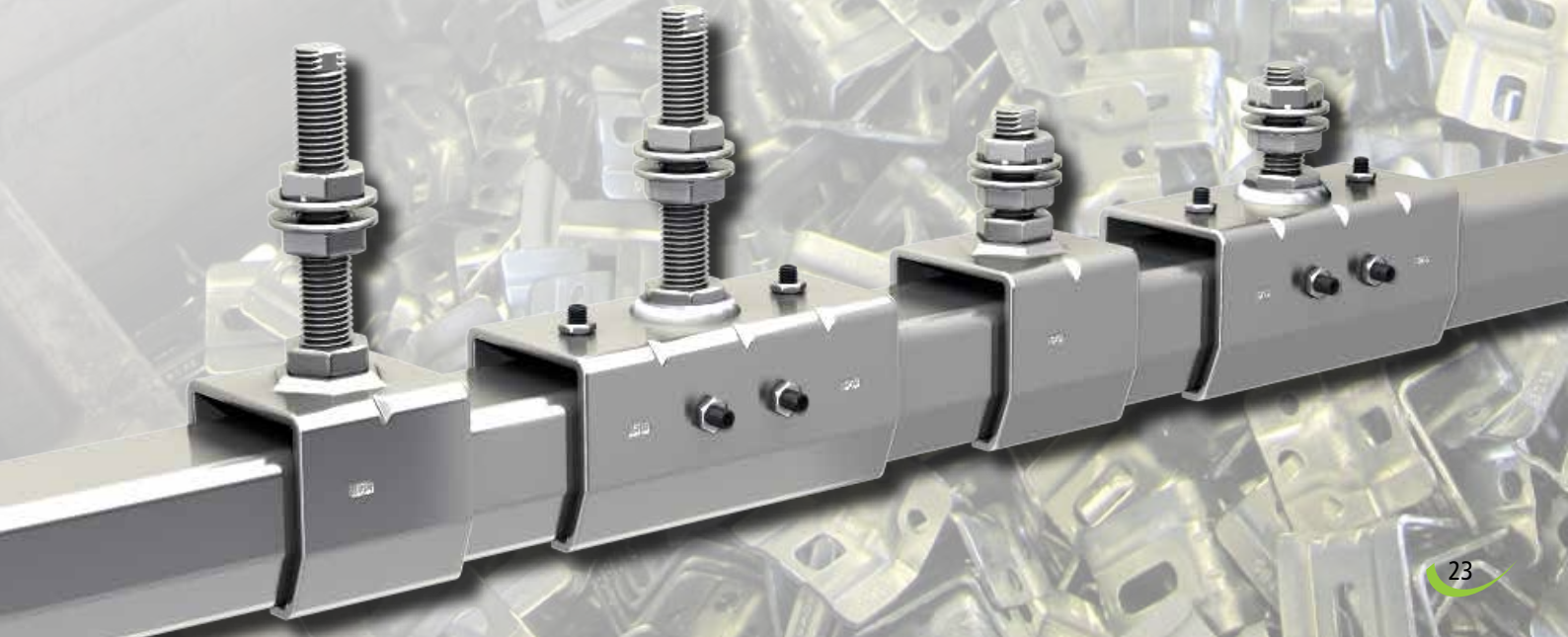
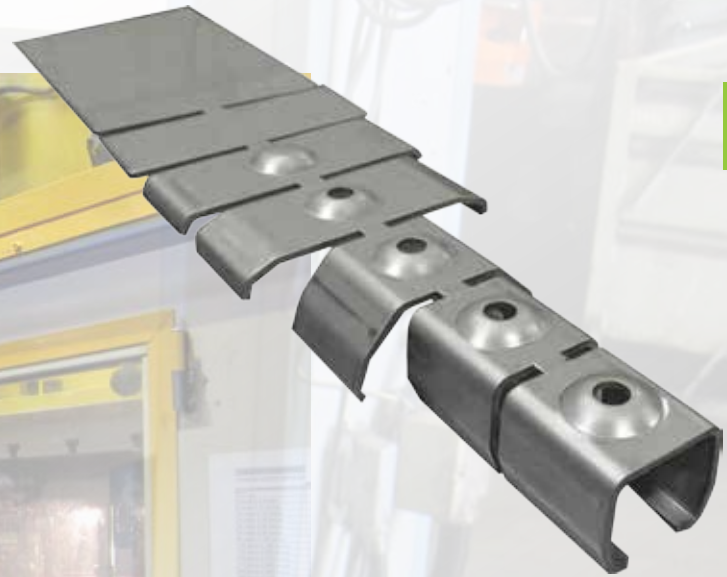

	ref	A	B	C	D	E	F
9030	9301AT	1400	1240	144	1000	196	258
9040	9401AT	1600	1440	159	1150	212	273
9050	9501AT	1885	1495	188	1150	240	302
9060	9601AT	2200	1780	205	1350	259	390

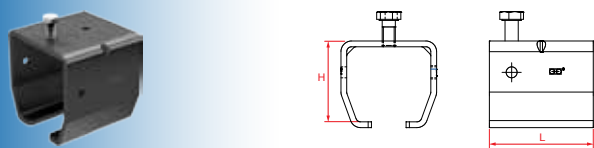

SUPPORT À SOUDER (ACIER BRUT)

 Weld on brackets (plain steel)
 Anschweissmuffe, Ausführung = blank



	ref	H	L
9010	9018	33.5	40
9030	9038	39.5	54
9040	9048	49	63
9050	9058	74.5	75
9060	9068	89	110
9070	9078	124	110

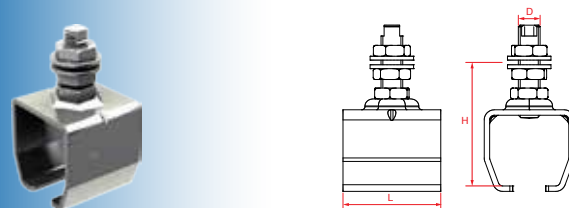

SUPPORT À TIGE FILETÉE COURTE

 Court adjustable brackets
 Höhenverstellbare Muffe kurz



	ref	D	L	H
9010	9011	M10	40	60 ±6
9030	9031	M14	54	72 ±5
9040	9041	M14	63	80 ±5
9050	9051	M20	75	109 ±3
9060	9061	M20	110	123 ±3

SUPPORT À TIGE FILETÉE LONGUE

 Long adjustable brackets
 Höhenverstellbare Muffe lang

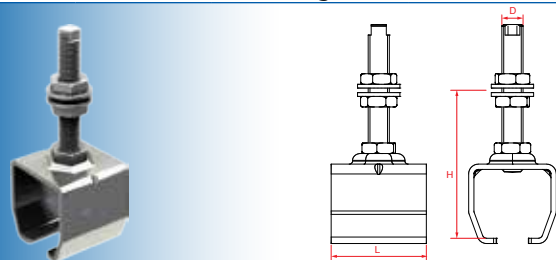

	ref	D	L	H
9010	9011L	M10	40	85 ±30
9030	9031L	M14	54	97 ±30
9040	9041L	M14	63	105 ±30
9050	9051L	M20	75	140 ±30
9060	9061L	M20	110	155 ±30
9070	9071L	M30	110	238 ±25

SUPPORT À SERRAGE AVEC VIS D'ACCROCHAGE

 Clamping brackets with bolt
 Höhenverstellbare Klemm-Muffe

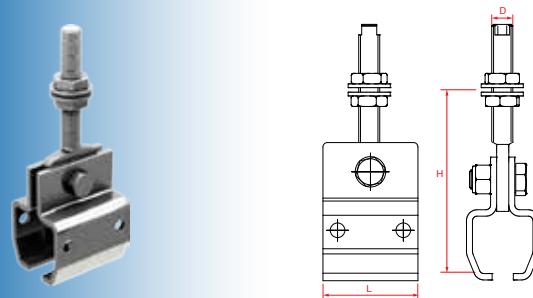

	ref	D	L	H
9030	9032	M14	54	135 ±25
9040	9042	M14	65	145 ±25
9050	9052	M20	90	183 ±35
9060	9062	M20	110	200 ±35
9070	9072	M30	110	278 ±50

SUPPORT À FIXATION MURALE

 Wall fixing brackets /  Wandmuffe

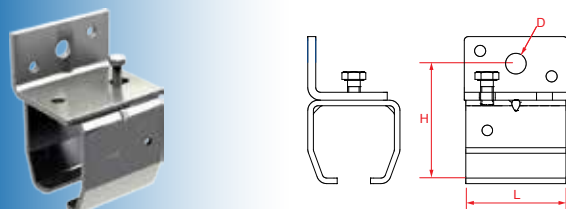

	ref	D	L	H
9010	9018V	9	40	47
9030	9038V	11	54	55
9040	9048V	13	63	70.5
9050	9058V	14	75	102
9060	9068V	21	110	124
9070	9078V	21	110	164

SUPPORT PLAFOND

 Roof fixing brackets /  Deckenmuffe

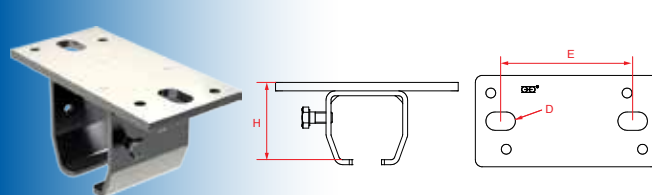

	ref	D	E	H
9010	9018H	9	78	36
9030	9038H	11	89	42.5
9040	9048H	13	102	52.5
9050	9058H	17	125	81.5
9060	9068H	21	158	96
9070	9078H	21	173	134

SUPPORT À SERRAGE NU

Clamping brackets
Klemm-Muffe

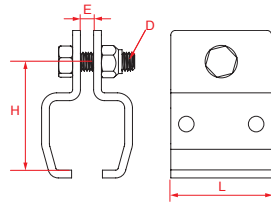

□	ref	D	E	L	H
9010	9012N	M10	6	40	49
9030	9032N	M12	8	54	59
9040	9042N	M12	8	65	70
9050	9052N	M16	10	90	89
9060	9062N	M16	10	110	104
9070	9072N	M16	10	110	142

SUPPORT

Brackets
Aufhängekombination

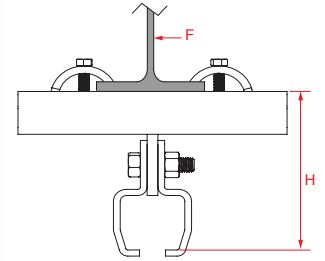

□	ref	H	F
9030	9037	119	IPE 80 - 240
9040	9047	130	IPE 80 - 240
9050	9057	168	IPE 80 - 240
9060	9067	204	IPE 80 - 240
9070	9077	242	IPE 80 - 240

SUPPORT SOUS POUTRELLE I

I beam brackets
Klemm-Muffe für IPE-Träger

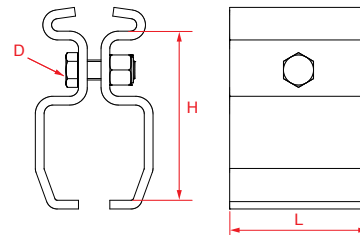

□	ref	D	L	H	IPN	IPE
9030	9037/80	M8	54	69	80	-
	9037/100	M8	54	69	100	80
	9027/120	M8	54	69	120	100
	9037/140	M8	54	69	140	120
9040	9047/80	M8	65	77	80	-
	9047/100	M8	65	77	100	80
	9047/120	M8	65	77	120	100
	9047/140	M8	65	77	140	120
	9047/160	M8	65	77	160	140
9050	9057/100	M16	90	115	100	80
	9057/120	M16	90	115	120	100
	9057/140	M16	90	115	140	120
	9057/160	M16	90	115	160	140
	9057/180	M16	90	115	180	160
9060	9067/140	M16	110	135	140	120
	9067/160	M16	110	135	160	140
	9067/180	M16	110	135	180	160
	9067/200	M16	110	135	200	180
9070	9077/200	M16	110	200	200	180

MANCHON DE RACCORDEMENT

 Jointing brackets /  Verbindungsmuffe

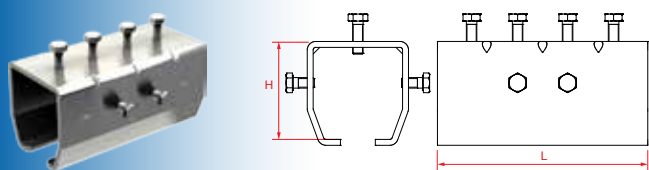

	ref	H	L
9010	9011M	33.5	90
9030	9031M	39.5	115
9040	9041M	49	135
9050	9051M	74.5	160
9060	9061M	89	205
9070	9071M	124	220

MANCHON À VIS HC CUVETÉES

 Jointing brackets
 Verbindungsmuffe mit HC Schraube

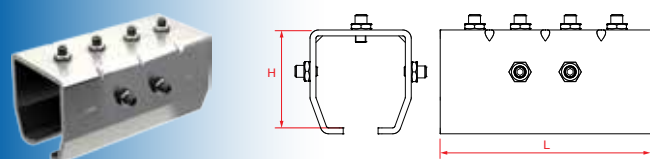

	ref	H	L
9030	9031MHC	39.5	115
9040	9041MHC	49	135
9050	9051MHC	74.5	160
9060	9061MHC	89	205
9070	9071MHC	124	220

MANCHON À TIGE FILETÉE COURTE

 Jointing brackets with short bolt
 Höhenverstellbare Verbindungsmuffe

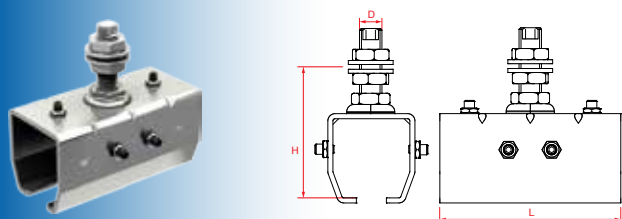

	ref	D	H	L
9040	9041MC	M14	80 ±5	135
9050	9051MC	M20	112 ±5	160
9060	9061MC	M20	127 ±5	205

MANCHON À TIGE FILETÉE LONGUE

 Jointing brackets with long bolt
 Höhenverstellbare Verbindungsmuffe

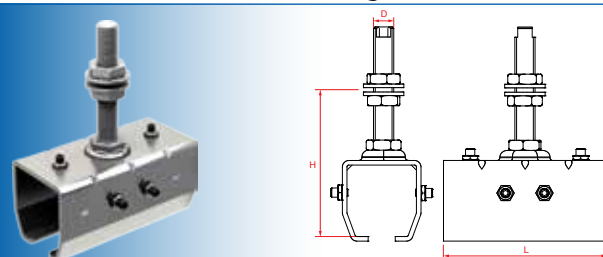

	ref	D	H	L
9030	9031ML	M14	97 ±30	115
9040	9041ML	M14	105 ±30	135
9050	9051ML	M20	140 ±35	160
9060	9061ML	M20	155 ±30	205

POSTE D'ENTRÉE

 Entrance/exit unit /  Einschiebestation

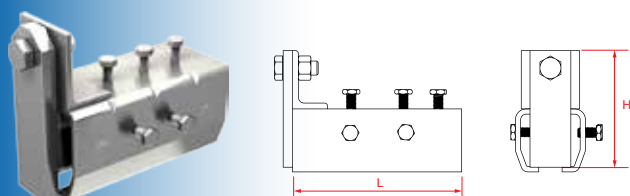

	ref	H	L
9030	9300PE	90	115
9040	9400PE	99	135
9050	9500PE	134.5	160
9060	9600PE	149	205



SUPPORT DE JONCTION PERPENDICULAIRE

Perpendicular jointing brackets
Muffe mit Trägerplatte Quer

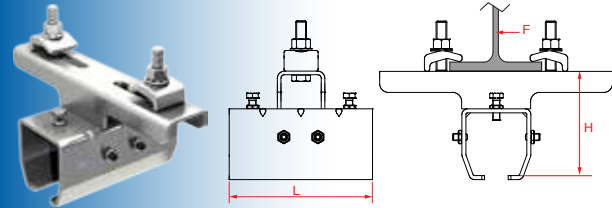

□	ref	H	L	F
9030	9037FMP	69	115	IPE 80 - 300
9040	9047FMP	77	135	IPE 80 - 300
9050	9057FMP	115	160	IPE 80 - 300
9060	9067FMP	135	205	IPE 80 - 300
9070	9077FMP	200	220	IPE 80 - 300

SUPPORT DE JONCTION EN LIGNE

In line jointing brackets
Muffe mit Trägerplatte Lang

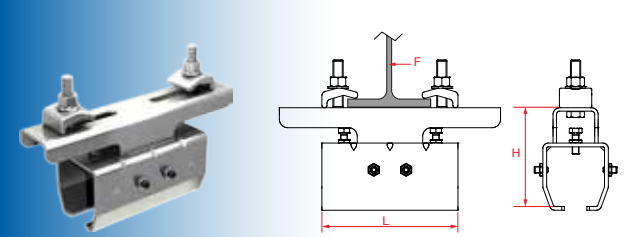

□	ref	H	L	F
9050	9057FML	115	160	IPE 80 - 300
9060	9067FML	135	205	IPE 80 - 300
9070	9077FML	200	220	IPE 80 - 300

SUPPORT DE FIXATION SOUS POUTRELLE I

Under I beam clamps
Klemm-Muffe für IPE-Träger

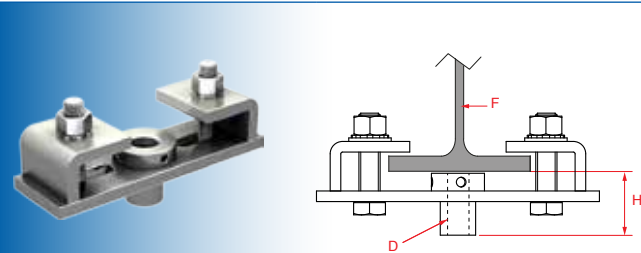

□	ref	D	H	F
9010	3537	M10	35	IPE 80 - 160
9030 / 9040	6262	M14	35	IPE 80 - 160
9050 / 9060	8577	M20	40	IPE 80 - 160

SUPPORT DE FIXATION SOUS POUTRELLE I LARGE

Under large I beam clamps
Befestigungsträger an IPE-Träger, Lang

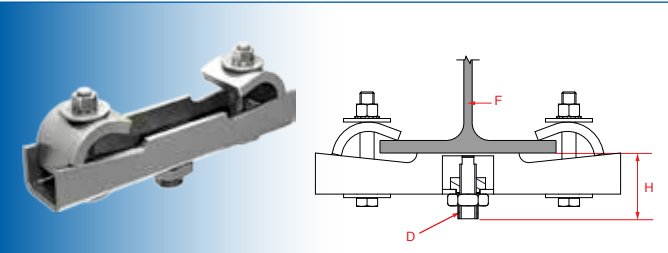

□	ref	D	H	F
9030 / 9040	9000TPV	M14	56	IPE 100 - 300
9030 / 9040	9000TPLV	M14	61	IPE 300 - 600
9050 / 9060	9000TPVR	M20	65	IPE 100 - 300
9050 / 9060	9000TPLVR	M20	65	IPE 300 - 600

Supports sous IPE / IPN utilisables avec supports à tige filetée page 24 et manchons à tige filetée page 26.

Under IPE / IPN hangers, used with threaded rod hangers page 24 threaded rod sleeves and page 26.

IPE/ IPN Träger können mit höhenverstellbaren Muffen S. 24 oder höhenverstellbaren Verbindungsmuffen S. 26 verwendet werden.





Fixations

Hanger / Befestigungsmaterial

CHARGES MAXI ADMISSIBLES PAR SUSPENTE

Maximum allowable loads by hanger

Max. Zulässige Last pro Zuganker



9030	40 daN
9040	150 daN
9050	250 daN
9060	500 daN



TIRANT

Threaded rod / Zuganker

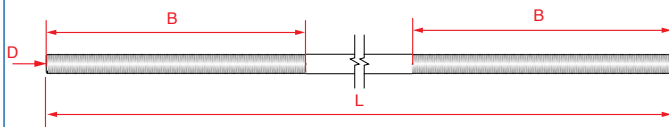

Ref	L	D	B
9000T/50	500	M12	500
9000T/100	1000	M12	300
9000T/150	1500	M12	300
9000T/200	2000	M12	300
9000T/250	2500	M12	300
9000T/300	3000	M12	300

SUPPORT À ÉCROU

Nut hanger / Aufhänger mit Mutter

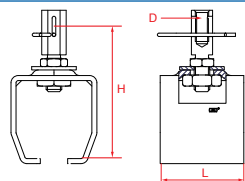

ref	D	H	L	
9030	9031TE	M12	93.5 ±7	54
9040	9041TE	M12	102 ±7	63
9050	9051TE	M12	118.5 ±7	75
9060	9061TE	M12	133.5 ±7	110

SUPPORT ARTICULÉ

Articulated hanger / Aufhängung mit Drehgelenk

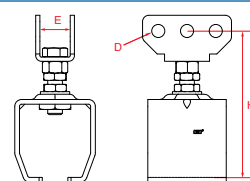

ref	D	H	E	
9030	9031TEA	12.5	111	29
9040	9041TEA	12.5	120	29
9050	9051TEA	12.5	140	29
9060	9061TEA	12.5	155	29

SUPPORT PLAFOND À ROTULE

Roof ball hanger

Decken-Aufhängung mit Kugelgelenk

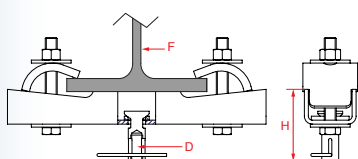

ref	D	H	F	
9030 → 9050	9000TPR	M12	72	IPE 100 - 300
9060	9000TPRR	M12	76	IPE 100 - 300

SUPPORT PLAFOND À CHAPE

Articulated roof hanger

Decken-Aufhängung mit Gabelkopf

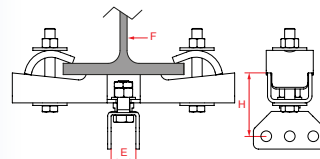

ref	D	H	F	
9030 → 9050	9000TPC	29	74	IPE 100 - 300
9060	9000TPCR	29	79	IPE 100 - 300

SUPPORT PLAFOND NU

Nude roof hanger / Decken-Aufhängung, einfach

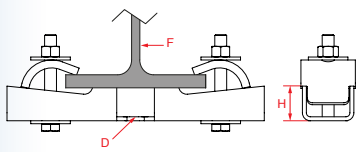

ref	D	H	F	
9030 → 9050	9000TPN	17.5	35	IPE 100 - 300
9060	9000TPNR	17.5	40	IPE 100 - 300

SUPPORT PLAFOND RALLONGÉ NU

Long nude Roof hanger

Verlängerte Decken-Aufhängung, einfach

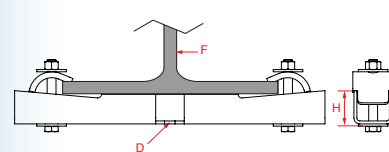
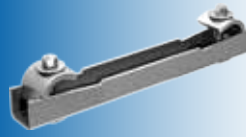

ref	D	H	F	
9030 → 9050	9000TPL	17.5	40	IPE 300 - 600
9060	9000TPLR	17.5	40	IPE 300 - 600

CHAPE FEMELLE

🇬🇧 Rod clevis / 🇩🇪 Gabelkopf mit Innengewinde

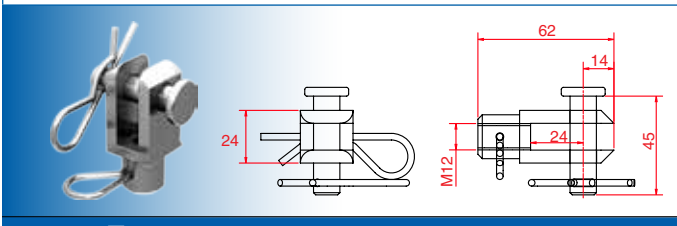

☐	ref
9030 → 9060	9000TCF

CHAPE MÂLE

🇬🇧 Rod eye / 🇩🇪 Gabelkopf mit Außengewinde

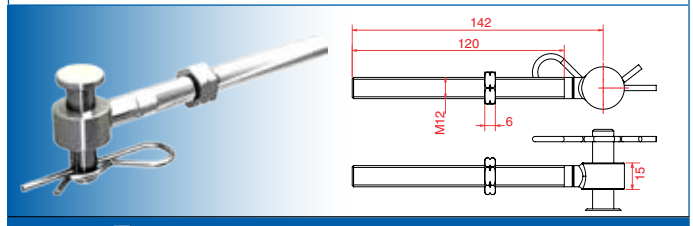

☐	ref
9030 → 9060	9000TCM

ACCOUPEMENT

🇬🇧 Coupling / 🇩🇪 Kupplung

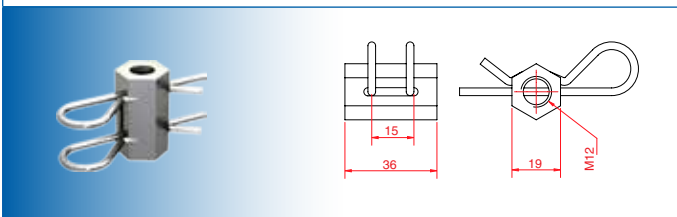

☐	ref
9030 → 9060	9000TM

LANTERNE

🇬🇧 Tensioner / 🇩🇪 Seilspanner

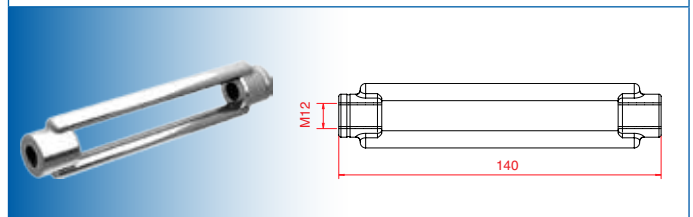

☐	ref
9030 → 9060	9000TL

ECROU À ROTULE

🇬🇧 Nut ball / 🇩🇪 Mutter mit Kugelgelenk

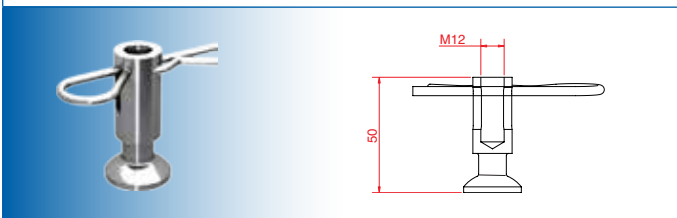

☐	ref
9030 → 9060	10501ER

ETRIER ARTICULÉ

🇬🇧 articulated bracket / 🇩🇪 Bügel mit Gelenk

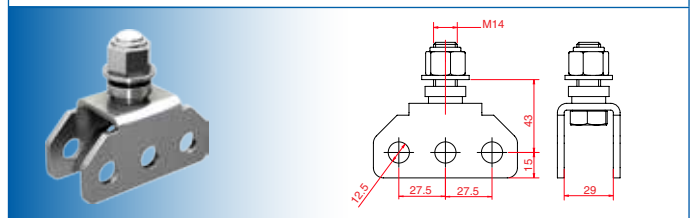

☐	ref
9030 → 9060	9000TEA

GABARIT DE PERÇAGE

🇬🇧 Drilling template / 🇩🇪 Bohrschablone



☐	ref
9030 → 9060	9000TGP

■ Gabarit de perçage à utiliser pour percer l'extrémité des tirants M12 pour mise en place des goupilles beta de sécurité.

🇬🇧 Use this drilling template to drill the ends of the M12 rods for implementation of safety pins.

🇩🇪 Diese Bohrschablone wird verwendet, um das Ende der M12 Zuganker zum Einsetzen von Sicherungssplinten aufzubohren.





MANCHONS DE DILATATION

Expansion units / Muffe gegen Schienenausdehnung

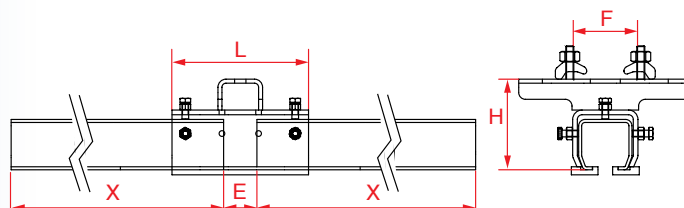
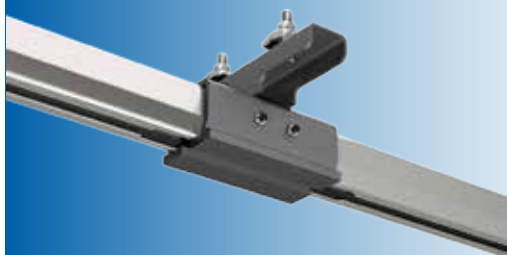

	ref	L	H	X	E	F
9040	9045MDIL	145	77	1000	50 max	IPE 80 - 300
9050	9055MDIL	180	115	1000	50 max	IPE 80 - 300
9060	9065MDIL	205	135	1000	50 max	IPE 80 - 300
9070	9075MDIL	220	200	1000	50 max	IPE 80 - 300

RAILS ESCAMOTABLES

Rail breakings / aushängbare Schiene - Schwenkstück

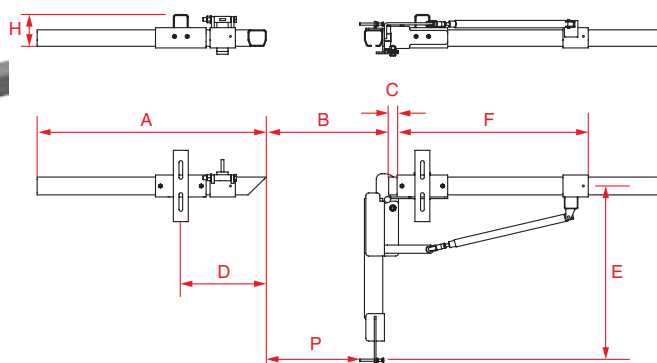
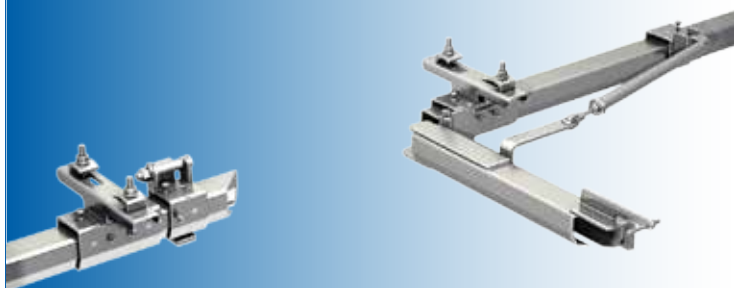

	ref	A	B	C	D	E	F	H	P
9040	9400RE	800	450	30	215	554	670	77	356
9050	9500RE	815	435	30	300	646	710	115	332
9060	9600RE	830	420	30	330	655	725	135	304

- raccords sur vérins double effet = 1/8F, distributeur pneumatique non fourni.
- Verbindungsstück auf doppeltem Windeffekt = 1/8F pneumatische Betätigung nicht enthalten.



CONSIGNES DE SECURITE:

Avant d'ouvrir ou fermer le rail, vérifier qu'il n'y a aucune charge à proximité immédiate des sécurités du rail escamotable. Ne jamais lancer une charge contre les sécurités. Ne jamais ouvrir le rail avec une charge disposée sur l'élément mobile sous risque de chute de pièces, risque important de destruction de l'appareil. Nous recommandons l'utilisation de régulateurs de débit disposés sur le vérin afin de contrôler la vitesse d'ouverture et de fermeture du rail mobile. VOIR NOTICE TECHNIQUE.

SECURITY INSTRUCTIONS:

Before opening or closing the rail, check that there is no load in the vicinity of the security of

the rail breaking. Never launch a load on the security. Never open the rail if a load is laid out on the mobile rail, major risk of falling parts, Important risk to destroy completely the unit. We recommend the use of volumetric governors fixed on the cylinder in order to control the speed of the opening and closing of the mobile rail. SEE OUR TECHNICAL NOTES.

SICHERHEITSHINWEIS:



















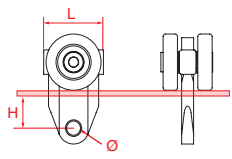



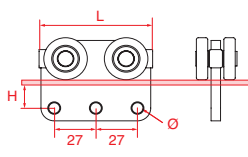



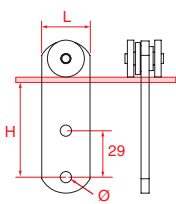



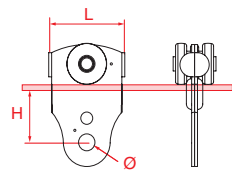

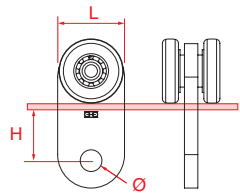

Bei Benutzung des Schwenkstükes muss unbedingt darauf geachtet werden, dass sich weder beim Öffnen noch beim Schließen eine Traglast im Öffnungsbereich befindet. Wir empfehlen hier die Benutzung der Absenkstation. SIEHE TECHNISCHE HINWEISE.



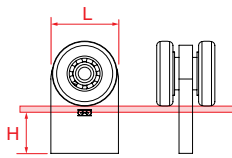

> Chariots

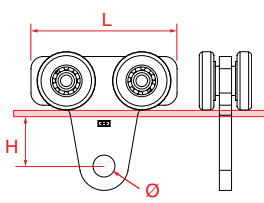
Trolleys / Transportwagen

 Désignation Description Beschreibung		 ref	 kg		 Ø	 H	 L				
	■ ■ CHARIOTS ARMATURE NYLON										
	 Trolleys NYLON body	9010	99711N	5	d	l	5,8	14		25	
	 Transporthänger Nylon	9010	9711N	8	d	b	5,8	14	25		
	■ ■ CHARIOTS ARMATURE NYLON										
	 Trolleys NYLON body	9010	99712N	10	d	l	5,8	14		60	
	 Transporthänger Nylon	9010	9712N	15	d	b	5,8	14	60		
	■ ■ CHARIOTS ARMATURE ACIER										
	 Trolleys Steel body	9010	99711R	5	a	bz	7	60		30	
	 Transporthänger Stahl	9010	99731R	20	a	bz	7	55	30		
	■ ■ CHARIOTS ARMATURE ACIER										
	 Trolleys Steel body	9010	99711	5	d	l	10	29		36	
	 Transporthänger Stahl	9010	9711	10	a	b	10	29		36	
			9030	99731	10	d	l	10		32.5	50
			9030	9731	20	a	b	10		32.5	50
			9030	9731N	13	bn	b	10		32.5	50
			9040	99741	20	d	l	14		45	65
			9040	9741	35	a	b	14		45	65
		9040	9741S	50	a	bp	14	45	65		
		9040	9741N	25	bn	b	14	45	65		
	■ ■ CHARIOTS ARMATURE ACIER										
	 Trolleys Steel body	9010	9711WRS	10	a	bp	6	17		25	
	 Transporthänger Stahl	9030	9731WRS	20	a	bp	10	28		30	
			9040	9741WRS	35	a	bp	14		34.5	40
			9050	9751WRS	100	a	bp	18		40	50
		9060	9761WRS	200	a	bp	22	49	70		
	■ ■ CHARIOTS ARMATURE ACIER										
	 Trolleys Steel body	9010	9711WRSO	10	a	bp	–	21		25	
	 Transporthänger Stahl	9030	9731WRSO	20	a	bp	–	25		30	
			9040	9741WRSO	35	a	bp	–		35	40
			9050	9751WRSO	100	a	bp	–		31.5	50
		9060	9761WRSO	200	a	bp	–	46	70		
	■ ■ CHARIOTS ARMATURE ACIER										
	 Trolleys Steel body	9010	9712WRS	20	a	bp	8	19		60	
	 Transporthänger Stahl	9030	9732WRS	40	a	bp	10	31		80	
			9040	9742WRS	70	a	bp	14		40	100
			9050	9752WRS	200	a	bp	18		42.5	120
			9060	9762WRS	400	a	bp	20		46	145
		9070	9772WRS	800	a	bp	25	73.5	210		

Désignation Description Beschreibung		ref	kg			E	H	L		
CHARIOTS ARMATURE ACIER										
	Trolleys Steel body	9010	9712WRSO	20	a	bp	19	23	60	
	Transporthänger Stahl	9030	9732WRSO	40	a	bp	30	26	80	
		9040	9742WRSO	70	a	bp	35	35	100	
		9050	9752WRSO	200	a	bp	45	32.5	120	
		9060	9762WRSO	400	a	bp	55	46	145	
		9070	9772WRSO	800	a	bp	72	74	210	
CHARIOTS ARMATURE ACIER										
	Trolleys Steel body	9010	99712	10	d	l	8,5	38	90	
	Transporthänger Stahl	9010	9712	20	a	b	8,5	38	90	
		9030	99732	20	d	bz	8,5	34	89	
		9030	9732	40	a	b	8,5	34	89	
		9030	9732N	25	bn	bp	8,5	34	89	
		9040	99742	35	d	l	14	43	118	
		9040	9742	70	a	b	14	43	118	
		9040	9742S	100	a	bp	14	43	118	
		9040	9742N	50	bn	bp	14	43	118	
		9050	99752	80	d	l	14	39	156	
		9050	9752	160	a	b	14	39	156	
		9050	9752S	200	a	bp	14	39	156	
		9050	9752N	100	bn	bp	14	39	156	
		9060	99762	160	d	l	14	32	156	
		9060	9762S	400	a	bp	14	32	156	

CHARGE PORTANTE DES CHARIOTS

Charge portante des chariots

Dans les tableaux des chariots, les forces maximales sont indiquées. Pour calculer la charge réelle admissible F, la force utile doit être divisée par le coefficient alpha.

$$F = \text{Force} / \alpha$$

Max load on trolleys

In the tables of the trolleys, the maximum load is indicated. To calculate the real load F, the load must be divided by the alpha parameter.

$$F = \text{load} / \alpha$$

Tragkraft der Transporthänger

In der Tabelle wird die maximale Tragkraft angegeben. Um die höchstzulässige Tragkraft F zu errechnen, muss die Kraft durch den Koeffizienten alpha dividiert werden.

$$F = \text{Kraft} / \alpha$$



Type	alpha
utilisation normale pas de chocs (déplacement manuel, 5 h par jour) normal use without shocks (manual hand drive, 5 h per day) normale Nutzung ohne Erschütterung (manuelle Bewegung, 5 h pro Tag)	1
utilisation normale avec chocs légers (déplacement manuel, 10 h par jour) normal use with light shocks (manual hand drive, 10 h per day) normale Nutzung mit leichter Erschütterung (manuelle Bewegung, 10 h pro Tag)	1.2
utilisation fréquente avec chocs légers (déplacement manuel, 16 h par jour) frequent use with light shocks (manual hand drive, 16 h per day) häufige Nutzung mit leichter Erschütterung (manuelle Bewegung, 16 h pro Tag)	1.3
utilisation intensive avec chocs ou installation automatique. 16 h par jour intensive use with shocks or automatic installation. 16 h per day intensive Nutzung mit Erschütterung oder automatischer Installation, 16 h pro Tag	2

Galets : d = delrin / a = acier / bn = bandage nylon
Roller : d = delrin / a = steel / bn = nylon ring
Rollen : d = Delrin / a = Stahl / bn = Nylonaufläche

Paliers : bz = bronze / l = lisse / b = billes / bp = billes de précision
Axle : bz = bronze / l = smooth axle / b = ball bearing / bp = precision ball
Lager : bz = Bronze / l = Flachachse / b = Kugellager / bp = Präzisionskugellager



Chariots

Trolleys / Transportwagen

 Désignation Description Beschreibung		ref	 kg			Ø	H	L		
■ ■ CHARIOTS										
 Trolleys Transporthänger		9040	9742SP	100	a	bp	14	48	120	
		9050	9752SP	200	a	bp	14	41	120	
		9060	9762SP	400	a	bp	16	49	145	
■ ■ CHARIOTS										
 Trolleys Transporthänger		9040	9742RS	100	a	bp	14	30	89	
		9050	9752RS	200	a	bp	18	43	128	
		9060	9762RS	400	a	bp	20	46	158	
■ ■ CHARIOTS À ROTULE ARMATURE ACIER										
 Trolleys with ball Transporthänger mit Kugelgelenk		9030	9831RT	20	a	b	M12	75	70	
		9040	9841RT	35	a	bp	M16	81	80	
		9050	9851SRT	100	a	bp	M20	107	100	
		9060	9861SRT	200	a	bp	M24	129	120	
■ ■ CHARIOTS À ROTULE ARMATURE ACIER										
 Trolleys with ball Transporthänger mit Kugelgelenk		9030	9832RT	40	a	b	M12	75	70	
		9040	9842RT	70	a	bp	M16	81	90	
		9050	9852SRT	200	a	bp	M20	107	110	
		9060	9862SRT	400	a	bp	M24	129	140	
■ ■ CHARIOTS ARMATURE ACIER										
 Trolleys Steel body Transporthänger Stahl		9010	99812	10	d	l	10.5	18	90	
		9010	9812	20	a	b	10.5	18	90	
		9030	99832	20	d	l	12.5	22	89	
		9030	9832	40	a	b	12.5	22	89	
		9030	9832N	25	bn	bp	12.5	22	89	
		9040	99842	35	d	l	15	23	118	
		9040	9842	70	a	b	15	23	118	
		9040	9842S	100	a	bp	15	23	118	
		9040	9842N	50	bn	bp	15	23	118	
		9050	99852	80	d	l	17	35	156	
		9050	9852	160	a	b	17	35	156	
		9050	9852S	200	a	bp	17	35	156	
		9050	9852N	100	bn	b	17	35	156	
		9060	99862	160	d	l	17	28	156	
		9060	9862S	400	a	bp	21	28	156	
■ ■ CHARIOTS ARMATURE ACIER										
 Trolleys Steel body Transporthänger Stahl		9040	9842SP	150	a	bp	14.5	32	98	
		9050	9852SP	250	a	bp	16.5	42	128	
		9060	9862SP	500	a	bp	21	47	158	
		9070	9872SP	1000	a	bp	31	44	223	
■ ■ CHARIOTS HAUTE TEMPÉRATURE										
						MAX 250°				
 high temperature Trolleys Transporthänger für Hochtemperatur		9040	9842HT	150	a	b	14	32	98	
		9050	9852HT	250	a	b	16.5	42	128	
		9060	9862HT	500	a	b	21	47	158	

Désignation Description Beschreibung	ref	kg			Ø	H	L	
CHARIOTS GL ARMATURE ACIER								
GL Trolleys Steel body	9040	9842GL	150	a	bp	14.5	42	90
Transporthänger GL Stahl mit seitlicher Führung	9050	9852GL	250	a	bp	16.5	55	107
	9060	9862GL	500	a	bp	20.5	62	130
CHARIOTS GL HAUTE TEMPÉRATURE								
MAX 250°								
High temperature GL Trolleys	9040	9842GLHT	150	a	b	14.5	42	90
	9050	9852GLHT	250	a	b	16.5	55	107
Transporthänger GL für Hochtemperaturen mit seitlicher Führung	9060	9862GLHT	500	a	b	20.5	62	130
CHARIOTS GLR								
GLR Trolleys	9040	9842GLR	70	a	bp	M16	92	90
Transporthänger GL mit seitlicher Führung und Kugelgelenk	9050	9852GLR	200	a	bp	M20	115	107
	9060	9862GLR	400	a	bp	M24	126	130
CHARIOTS GLR HAUTE TEMPÉRATURE								
MAX 250°								
High temperature GLR trolleys	9040	9842GLRHT	70	a	b	M16	92	90
	9050	9852GLRHT	200	a	b	M20	115	107
Transporthänger GL für Hochtemperaturen	9060	9862GLRHT	400	a	b	M24	126	130

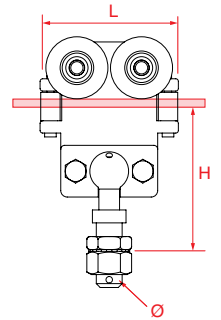
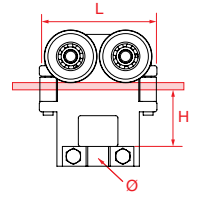

Galets : d = delrin / a = acier / bn = bandage nylon
Roller : d = delrin / a = steel / bn = nylon ring
Rollen : d = Delrin / a = Stahl / bn = Nylonaufläc

Paliers : bz = bronze / l = lisse / b = billes / bp = billes de précision
Axle : bz = bronze / l = smooth axle / b = ball bearing / bp = precision ball
Lager : bz = Bronze / l = Flachachse / b = Kugellager / bp = Präzisionskugellager

ANNEAUX							
Rings / Ring							
	ref	Ø1	Ø	H	H1	kg	
	9010	8331	25	10	48	13	25
	9030	8531	29	12	57	16	60
	9040	8631	30	14	60	19	150
	9050/9060	8731	35	16	73	25	250
	9050	8831	35	16	67	19	250
	9060	8831S	40	20	80	25	500
	9070	8931	60	30	115	31	1000

CROCHETS							
Hooks / Haken							
	ref	Ø	E	H	H1	kg	
	9040	8632	14	20	116	19	150
	9050/9060	8732	16	20	122	25	250
	9050	8832	16	20	116	19	250
	9060	8832S	20	20	123	25	500
	9070	8932	30	20	128	31	1000

Désignation Description Beschreibung	ref	kg				H	L		
■ ■ CHARIOT DOUBLE À CROCHET									
Double trolleys with hook Nur für Schubladenweichen doppelter Transportwagen mit Haken	9040	9848	140	a	b	8822S	208		288
	9040	9848S	200	a	bp	8822S	208		288
	9050	9858	320	a	b	8822S	204		326
	9050	9858S	400	a	bp	8822S	204		326
	9060	9868S	500	a	bp	8822S	197	326	
■ ■ CHARIOT DOUBLE À ANNEAU									
Double trolleys with ring Nur für Schubladenweichen doppelter Transportwagen mit Ring	9040	9849	140	a	b	8821S	191		288
	9040	9849S	200	a	bp	8821S	191		288
	9050	9859	320	a	b	8821S	187		326
	9050	9859S	400	a	bp	8821S	187		326
	9060	9869S	500	a	bp	8821S	180	326	
■ ■ CHARIOTS À 4 INDEXATIONS À 90°									
INDEXED TROLLEYS - 4 x 90° Transporthänger mit 4-facher Einrastung, 90°	9040	9842SI	100	a	bp	12	95		158
	9050	9852SI	200	a	bp	14	108		158

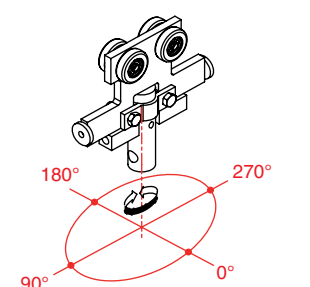

Galets : d = delrin / a = acier / bn = bandage nylon
Roller : d = delrin / a = steel / bn = nylon ring
Rollen : d = Delrin / a = Stahl / bn = Nylonauffläche
Paliers : bz = bronze / l = lisse / b = billes / bp = billes de précision
Axle : bz = bronze / l = smooth axle / b = ball bearing / bp = precision ball
Lager : bz = Bronze / l = Flachachse / b = Kugellager / bp = Präzisionskugellager

■ ■ BUTÉE COURTE Short stoppers / Stopper kurz				
	ref	E	H	L
9010	9118	17.5	24	25
9030	9138	24	28	33
9040	9148	28	35	39.5
9050	9158	35	50	55

■ ■ BUTÉE LONGUE Long stoppers / Stopper lang				
	ref	E	H	L
9030	9139	20	23	72
9040	9149	30	30	78
9050	9159	40	48	113
9060	9169	50	60	104
9070	9169	50	60	104

■ ■ PALONNIERS À ANNEAU

🇬🇧 Load bars with ring / 🇩🇪 Traverse mit Ring

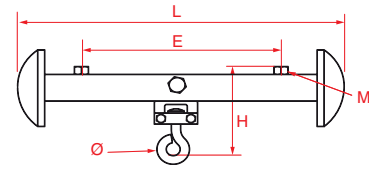

☐	ref	kg	kg		M	H	E	L
9030	9839PAL	40	80	8621	M12	158	180	292
9040	9849PAL	70	140	8821	M16	189	300	443
9050	9859PAL	200	400	8821S	M20	227	420	598
9060	9869PAL	400	800	8921	M24	281	500	700

■ ■ PALONNIERS À CROCHET

🇬🇧 Load bars with Hook / 🇩🇪 Traverse mit Haken

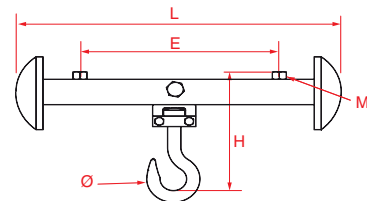

☐	ref	kg	kg		M	H	E	L
9030	9838PAL	40	80	8622	M12	158	180	292
9040	9848PAL	70	140	8822	M16	191	300	443
9050	9858PAL	200	400	8822S	M20	245	420	598
9060	9868PAL	400	800	8922	M24	226	500	700

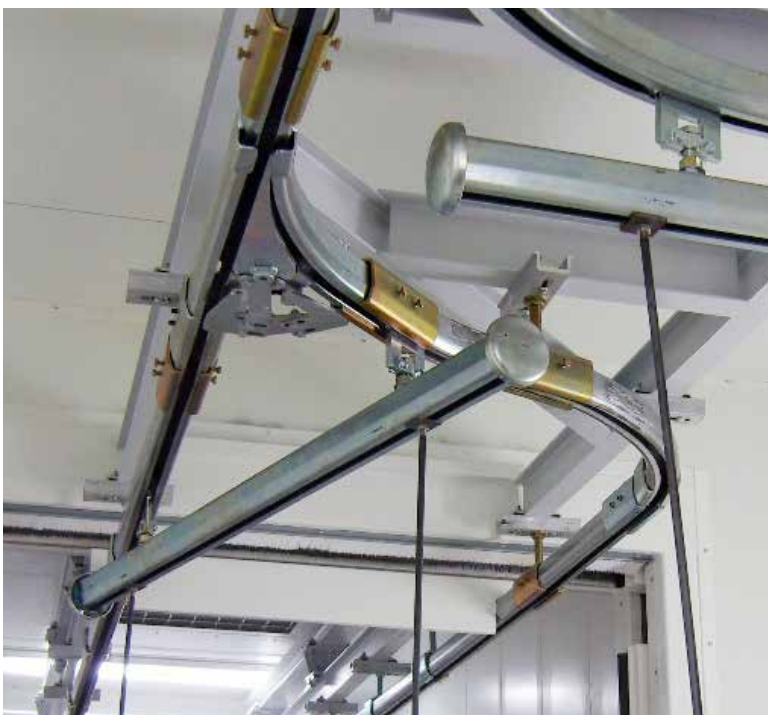

■ ■ Les chariots en rouge sont à commander séparément. Utiliser uniquement des chariots à rotule !

🇬🇧 The trolleys in red are to be ordered separately. Use only trolleys with ball.

🇩🇪 Die rot eingezeichneten Rollapparate müssen separat bestellt werden. Nur Rollapparate mit Kugelgelenk verwenden!

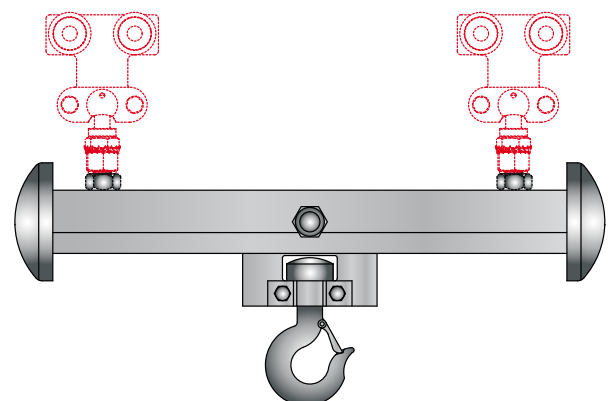

■ ■ STATION ÉLÉVATRICE

Appareil destiné à être raccordé à une installation de convoyage par monorail.

Cet appareil sert à descendre et monter une charge supportée par un ou plusieurs chariots, ensemble déplacé manuellement dans un monorail.

Cet appareil peut être utilisé pour soulever ou déposer des charges au sol ou sur un support quelconque.

Cet appareil est conforme au décret du 23 août 1947.

🇬🇧 LIFTING STATION

Apparatus intended to be connected to an conveying by monorail installation.

This apparatus is used for descending and lifting a load supported by one or more trolleys, moved together manually in a monorail.

This apparatus can be used to raise or deposit loads posed on the ground or on an unspecified support.

This apparatus is in conformity with the decree of August 23, 1947.

🇩🇪 HUBSTATION

Gerät zum Anschluss an eine Hängebahn. Dieses Gerät dient dazu, eine von einem bzw. mehreren Laufwagen getragene Last, zu heben bzw. abzusenken, wobei das Ganze von Hand auf einer Hängebahn verfahren wird.

Dieses Gerät kann zum Heben bzw. Absenken von Lasten, die auf dem Boden bzw. auf einem beliebigen Träger abgestellt sind, eingesetzt werden.

Dieses Gerät entspricht der Verordnung vom 23. August 1947.



STATIONS ÉLÉVATRICES STANDARDS

Standard drop sections / Hub- und Absenkstationen Standard

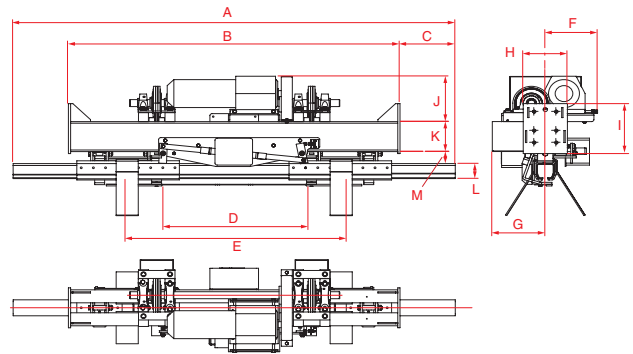

□	ref	A	B	C	D	E	F	G	H	I	J	K	L	M	kg
9040	9042SE	1950	1500	250	660	950	200	240	200	250	224	150	43.5	60	150 daN
9050	9052SE	2000	1500	250	658	1027	242	237	200	250	227	150	60	60	250 daN
9060	9062SE	2000	1500	250	658	1000	237	236	200	250	227	150	75	60	500 daN

STATIONS ÉLÉVATRICES RALLONGÉES

Long drop sections / Absenkstationen, lange Ausführung

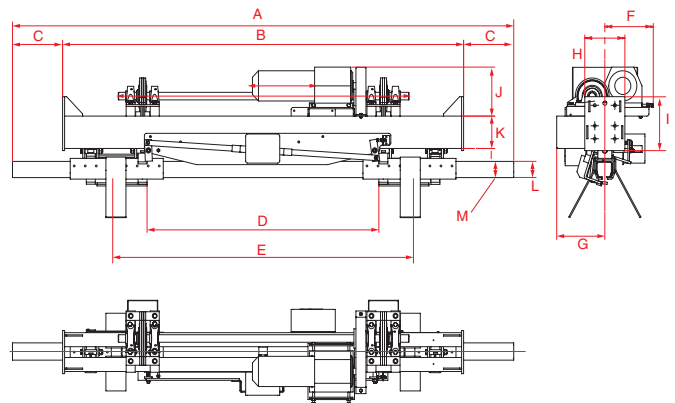
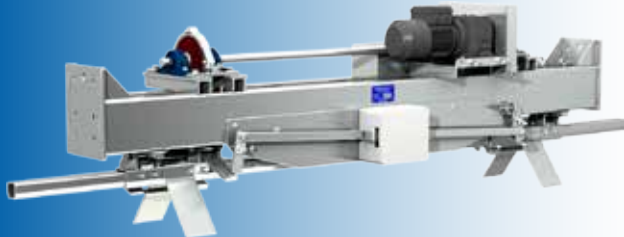

□	ref	A	B	C	D	E	F	G	H	I	J	K	L	M	kg
9040	9042SE1500	2450	2000	225	1160	1450	180	237	200	250	227	150	43.5	60	150 daN
9050	9052SE1500	2500	2000	250	1158	1527	242	237	200	250	227	150	60	60	250 daN
9060	9062SE1500	2500	2000	250	1156	1500	237	236	200	250	227	150	75	60	500 daN



Nos stations sont équipées de boîtes à boutons alimentées en 380V, à utiliser en intérieur.
Pour cotes et informations complémentaires, veuillez nous consulter.

Our drop sections are equipped with a 380 V push button box, indoor use only.
For complementary dimensions and information, please consult us. /

Unsere Stationen sind ausgestattet mit einem Schaltkasten, gespeist mit 380 V; zur Nutzung in Innenräumen.
Für zusätzliche Informationen wenden Sie sich bitte an uns.



Levage et automatisation

Lifting and automation / heben und automatisierung

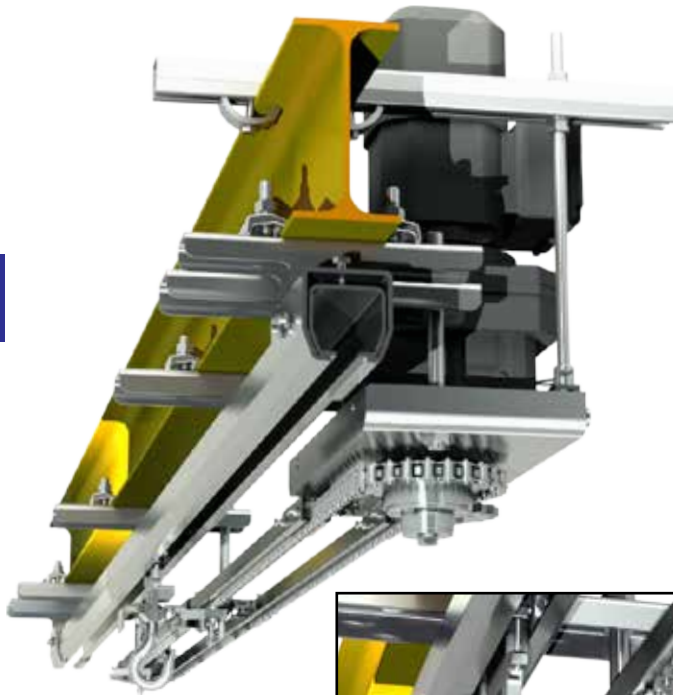

TRANSFERT LATÉRAL

Les Installations Manton peuvent être équipées de notre système de transfert latéral.

Ce système permet de faire avancer une charge de manière automatique sur une distance déterminée. Cela permet de faire avancer un palonnier ou un chariot dans une cabine de peinture ou dans un four par exemple.

Le transfert latéral Manton est adaptable en standard sur toute la gamme Hercule, du profil 9040 jusqu'au 9060 inclus.

Un moteur muni d'un limiteur de couple entraîne une chaîne équipée de taquets d'entraînement et une tension permet de clore le système. Ce sont ces taquets d'entraînement qui permettent de mouvoir les chariots disposés dans le profil Hercule.



LATERAL TRANSFER

Manton installations can be equipped with our lateral transfer system. This system allows to move forward a load in a automatic way on 'a determined distance.

It allows to move forward a load bar or a trolley in a painting cabin or in an oven for example.

The lateral transfer Manton is adaptable on all Hercules range, from 9040 until 9060 track.

A drive unit equipped with a torcq limiteur pull a chain equipped with pusher dogs and a tension unit close the system.

These pusher dogs allows to drive trolleys disposed in Hercules profiles.

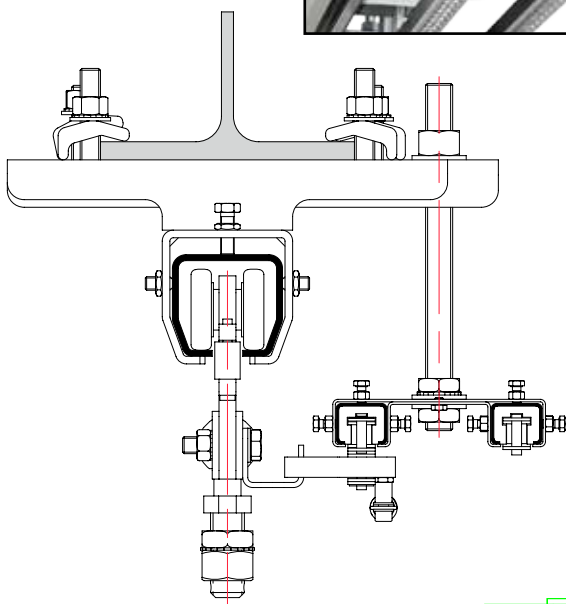

SEITLICHE MITNAHME

Die Anlagen von Manton können mit unseren seitlichen Mitnehmer ausgestattet werden.

Mit diesem System kann eine Last automatisch über eine bestimmte Entfernung befördert werden. So ist es möglich, eine Lasttraverse bzw. einen Laufwagen z.B. in einer Farbspritzkabine oder in einem Ofen fortzubewegen.

In der Standardausrüstung ist der seitliche Mitnehmer von Manton, außer dem Profil 9010, mit dem gesamten Programm «Hercule» einsetzbar. Der mit einem Drehmomentbegrenzer ausgestattete Motor treibt eine mit Antriebsmitnehmern versehene Kette an, wobei das System durch ein Spannelement geschlossen wird. Durch die Antriebsmitnehmer können die im Hercule-Profil eingehängten Laufwagen bewegt werden.

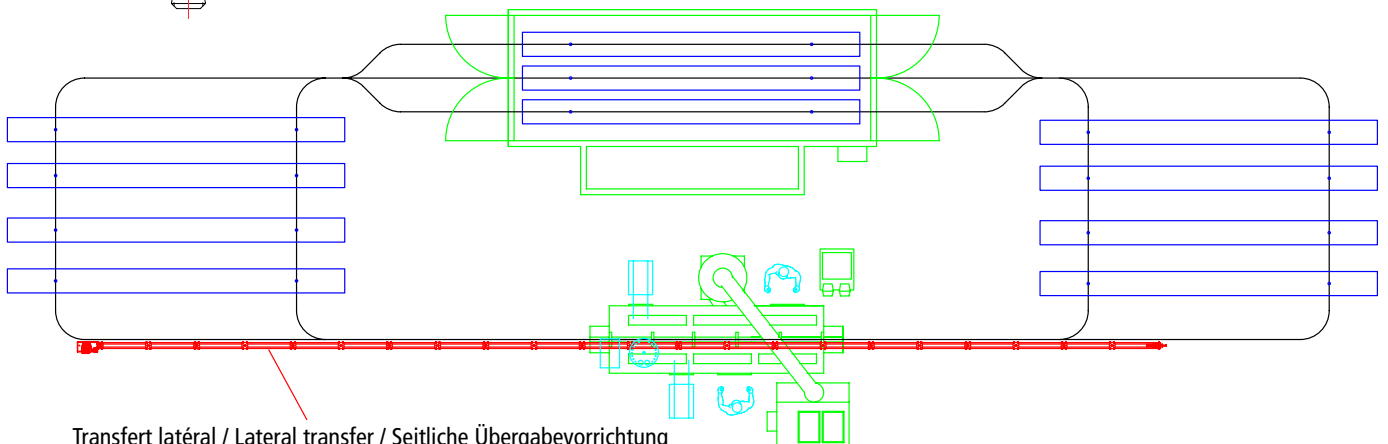

Transfert latéral / Lateral transfer / Seitliche Übergabevorrichtung

GROUPES D'ENTRAÎNEMENT

Drive unit / Antriebsaggregat

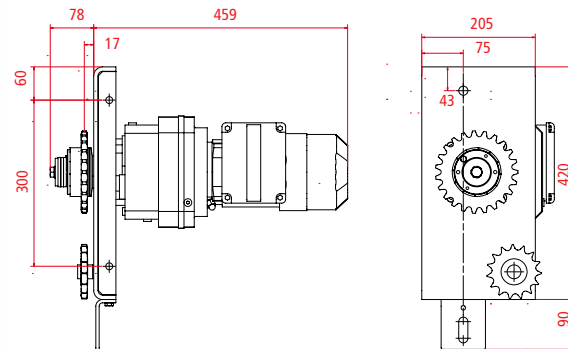

ref	Désignation / Designation / Beschreibung
9040 → 9060 9909D	Groupe d'entraînement à droite / Right drive unit / Laufrichtung rechts
9040 → 9060 9909G	Groupe d'entraînement à gauche / Left drive unit / Laufrichtung links

RAILS DE TRANSFERT

Transfer track / Übergabeschiene

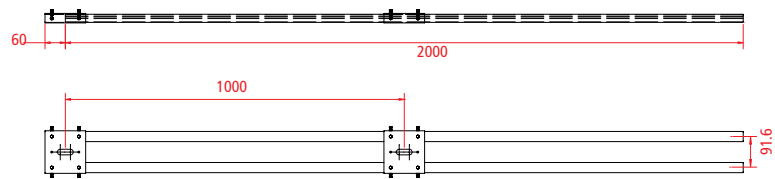
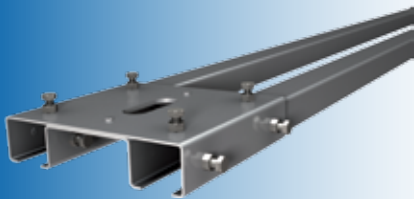

ref	Désignation / Designation / Beschreibung
9040 → 9060 9900/200	Rail de transfert standard / Standard transfer track / Standardübergabeschiene
9040 → 9060 9900HT/200	Rail de transfert haute température / high temperature transfer track / Übergabeschiene für hohe Temperaturen

COURBES

Curves / Bogen

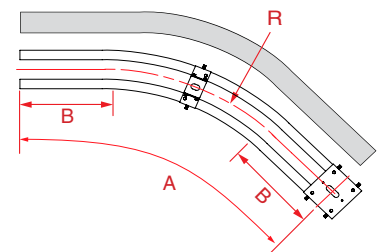
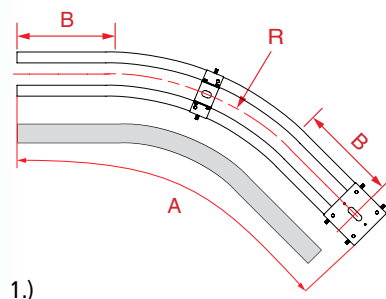
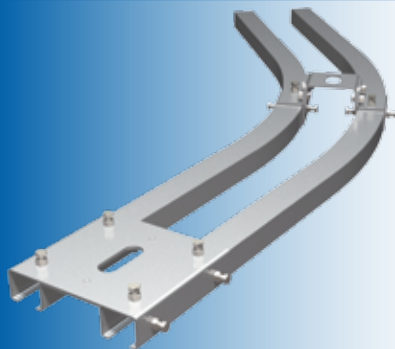

ref	A	B	R
1.) Courbes extérieures / External curves / Bogen Aussen			
9040 → 9060 9900C45EXT	45°	245	725
9060 9960C45EXT	45°	245	925
2.) Courbes intérieures / Internal curves / Bogen Innen			
9040 → 9060 9900C45INT	45°	245	475
9060 9960C45INT	45°	245	675



TENSION

Tension unit / Spannelement

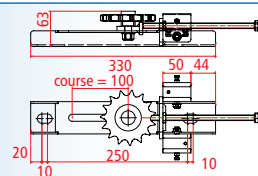

ref

Désignation / Designation / Beschreibung

9040 → 9060

9905

Tension / Tension unit / Spannung

SUSPENTE DE TRANSFERT

Transfer hanger / Übergabelterung

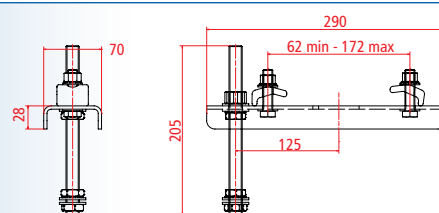
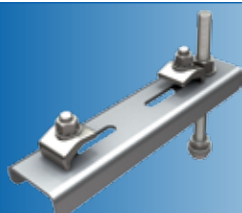

ref

Désignation / Designation / Beschreibung

9040 → 9060

9907

Suspente de transfert / Transfer hanger / Übergabelterung

CHAÎNE DE TRANSFERT ET TAQUET D'ENTRAÎNEMENT

Transfer hanger and Pusher dog / Förderkette und Antriebskette

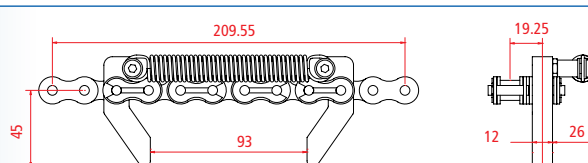
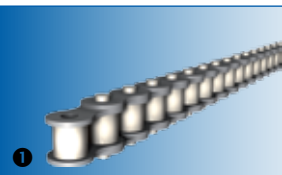

ref

Désignation / Designation / Beschreibung

① Chaîne de transfert / Transfer hanger / Förderkette

9040 → 9060

9910/500

Chaîne de transfert Lg = 500 cm / Drive chain L = 500 cm / Förderkettelänge 500 cm

② Taquet d'entraînement / Pusher dog / Antriebskette

9040 → 9060

9908

Taquet d'entraînement / Pusher dog / Antriebskette

PLAQUETTES DE CHARIOTS

Trolleys bar / Laufwagenplatten

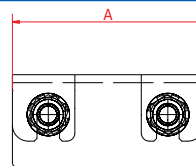
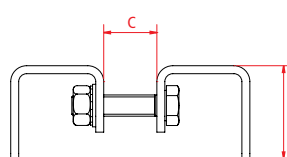

ref

A

D

C

9842GL

9911

72

35

14 - 20

9842GLR

9911

72

35

14 - 20

9852GL

9911

72

35

14 - 20

9852GLR

9912

75

37

18

9862GL

9913

80

27

18

9862GLR

9914

96

30

24

CONVOYEUR OMEGA

CONVEYOR OMEGA

KETTENFÖRDERER OMEGA

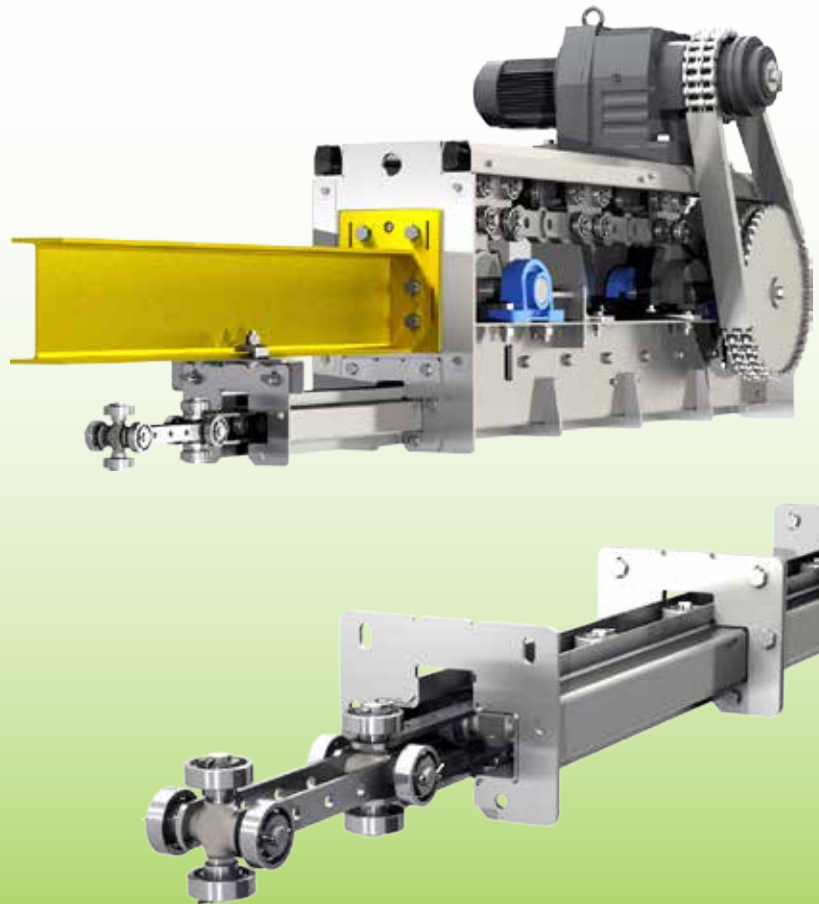
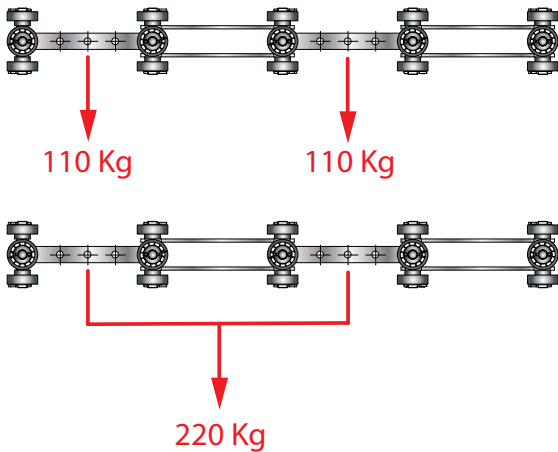

demandez notre documentation / ask our documentation / fragen sie nach unserer Dokumentation

CONVOYEUR 9050

9050 CONVEYOR

9050 KETTENFÖRDERER

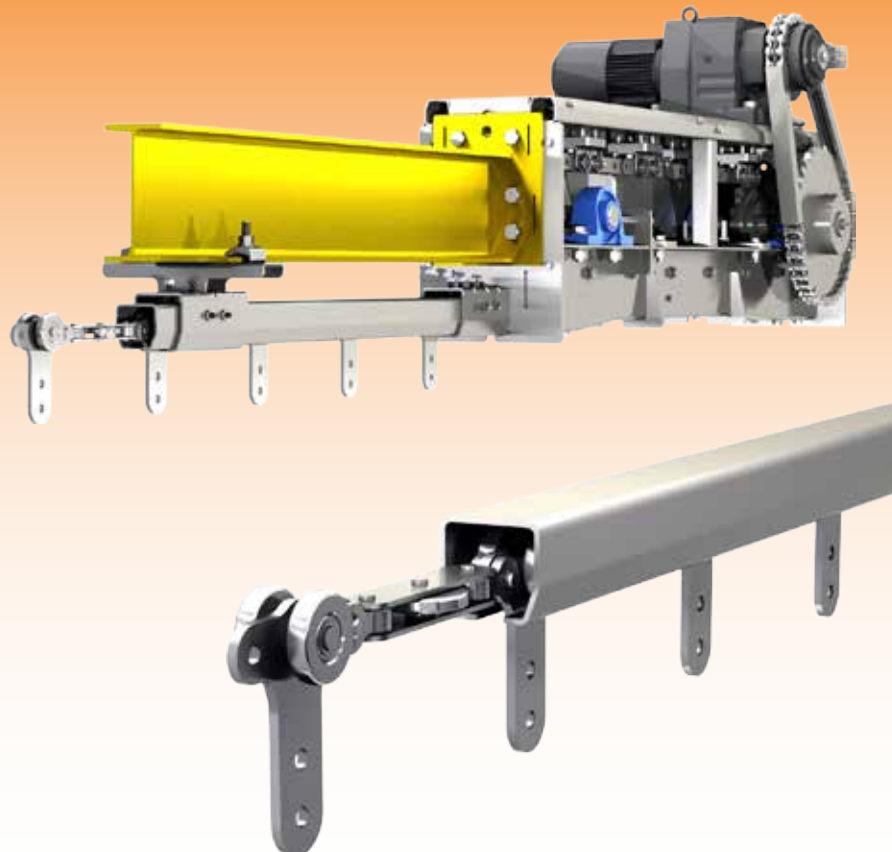
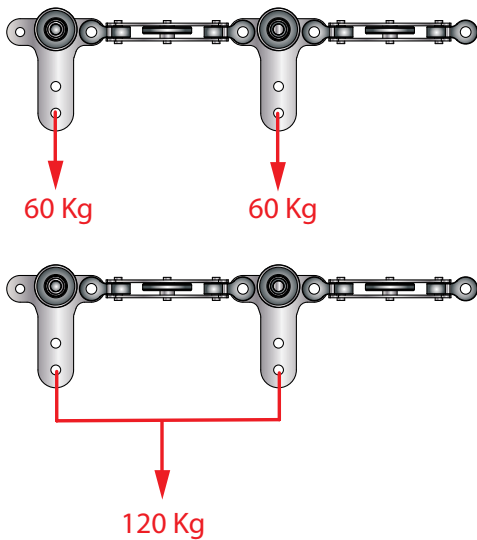

RAILS

Tracks / Schienen

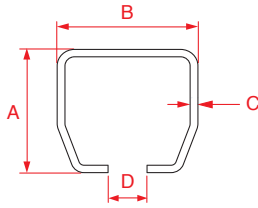

	304L	316L	A	B	C	D
9010	9010XA2/6	9010XA4/6	28	30	1.5	10
9030	9030XA2/6	9030XA4/6	35	40	2.5	12
9040	9040XA2/6	9040XA4/6	43.5	48.5	3	15
9050	9050XA2/6	-	60	65	3.5	18

COURBES HORIZONTALES

Horizontal Curves / Bogen horizontal

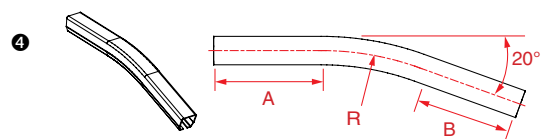
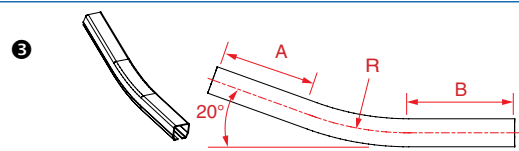
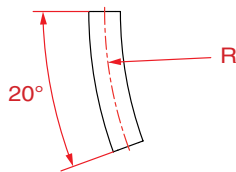
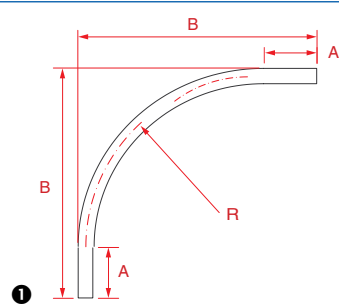

	304L	316L	A	B	R
1 Courbes horizontales à 90° / Horizontal curves at 90° / Bogen 90°, horizontal					
9010	9010CXA2	9010CXA4	360	375	500
9030	-	9030CXA4	430	1050	600
9040	-	9040CXA4	426	1050	600
2 Courbes horizontales à 20° / Horizontal curves at 20° / Bogen 20°, horizontal					
9030	9030CSXA2	9030CSXA4	-	-	600
3 Courbes verticales à 20° / Vertical curves at 20° / Bogen 20°, vertikal					
9030	9030CBXA2	9030CBXA4	205	205	600
4 Courbes verticales à 20° / Vertical curves at 20° / Bogen 20°, vertikal					
9030	9030CHXA2	9030CHXA4	205	205	600

SUPPORT À SOUDER

Weld on brackets
Anschweissmuffe

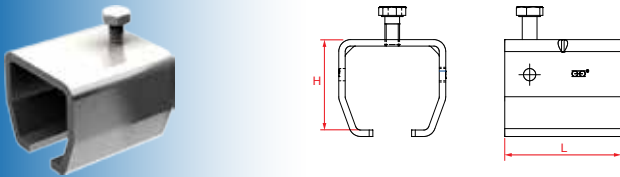

□	304L	316L	H	L
9010	9018XA2	9018XA4	32	40
9030	9038XA2	9038XA4	39.5	54
9040	9048XA2	9048XA4	49	65
9050	9058XA2	-	68	90

SUPPORT À TIGE FILETÉE

Adjustable brackets
Höhenverstellbare Muffe



□	304L	316L	D	L	H
9010	9011XA2	9011XA4	M10	40	58 ±5
9030	9031XA2	9031XA4	M14	54	72 ±5
9040	9041XA2	9041XA4	M14	65	81 ±5
9050	9051LXA2	-	M20	80	139 ±30

SUPPORT À FIXATION MURALE

Wall fixing brackets
Wandmuffe

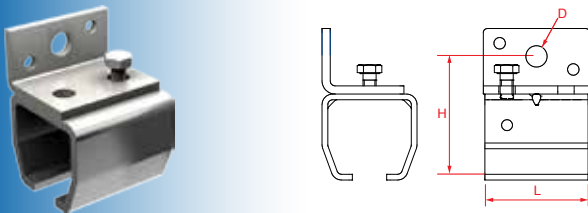

□	304L	316L	D	L	H
9010	9018VXA2	9018VXA4	9	40	46
9030	9038VXA2	9038VXA4	11	54	56
9040	9048VXA2	9048VXA4	13	65	72
9050	9058VXA2	-	14	90	96

SUPPORT À SERRAGE NU

Clamping brackets
Klemm-Muffe

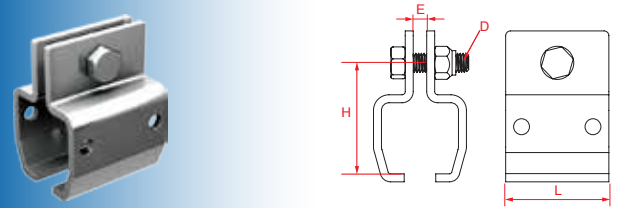

□	ref	D	E	L	H
9030	9032NXA2	M12	8	54	59
9040	9042NXA2	M12	8	65	70
9050	9052NXA2	M16	10	90	89

SUPPORT PLAFOND

Roof fixing brackets
Deckenmuffe

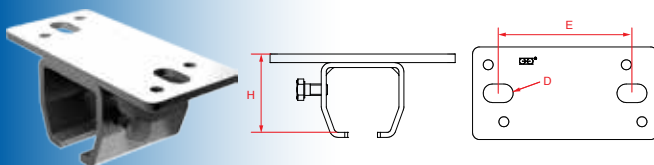

□	304L	316L	D	E	H
9010	9018HXA2	9018HXA4	9	70	35
9030	9038HXA2	9038HXA4	11	81	43.5
9040	9048HXA2	9048HXA4	13	94	54
9050	9058HXA2	-	17	125	74

MANCHON DE RACCORDEMENT

Joining brackets
Verbindungsmuffe

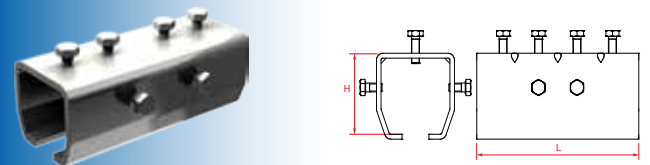

□	304L	316L	H	L
9010	9011MXA2	9011MXA4	32	80
9030	9031MXA2	9031MXA4	39.5	115
9040	9041MXA2	9041MXA4	49	145
9050	9051MXA2	-	68	180

 Désignation Description Beschreibung		ref 304L	ref 316L	kg			Ø	H	L	
	9030	99731XA2	99731XA4	10	d	l	10	33.5	49	
	9010	99712XA2	-	10	d	bz	8.2	38	87	
	9030	99732XA2	99732XA4	20	d	bz	8.2	33.5	89	
	9030	9732XSA2	9732XSA4	50	a	bp	8.2	33.5	89	
	9040	9742XSA2	9742XSA4	100	a	bp	14	43	118	
	9030	99832XA2	99832XA4	20	d	bz	12.5	22	89	
	9030	9832XSA2	9832XSA4	50	a	bp	12.5	22	89	
	9040	9842XSA2	9842XSA4	100	a	bp	15	23	118	
	9040	9742WRXSA2	9742WRXSA4	100	a	bp	14	40	100	
	9050	9752WRXSA2	-	200	a	bp	18	43	128	
	9040	9842XSPA2	9842XSPA4	100	a	bp	14.5	32	98	
	9050	9852XSPA2	-	200	a	bp	16.5	42	128	

BUTÉE COURTE

Short stoppers Stopper kurz

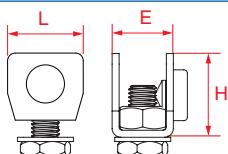

	304L	316L	C	H	L
9010	9118XA2	9118XA4	17.5	24	25

Galets : d = delrin / a = acier
 Roller : d = delrin / a = steel
 Rollen : d = Delrin / a = Stahl

Paliers : bz = bronze / l = lisse / bp = billes de précision
 Axle : bz = bronze / l = smooth axle / bp = precision ball
 Lager : bz = Bronze / l = Flachachse / bp = Präzisionskugellager

BUTÉE LONGUE

Long stoppers / Stopper lang

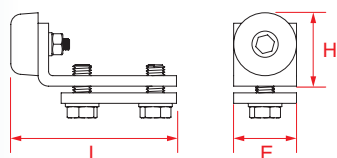

	304L	316L	E	H	L
9030	9139XA2	9139XA4	20	23	72
9040	9149XA2	9149XA4	30	30	78
9050	9159XA2	-	40	48	115

ANNEAUX

Rings / Ring

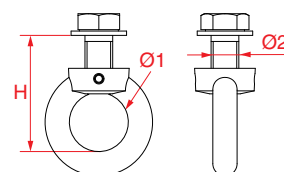

	304L	Ø1	Ø2	H	kg
9030	8521XA2	29	12	57	50
9040	8621XA2	30	14	60	100
9050	8821XA2	34	16	67	200

■ ■ Grâce à son profil HERCULE, Manton propose aussi une large gamme de matériel de levage: poutres roulantes, potences, accessoires d'électrification.
DEMANDEZ NOTRE DOCUMENTATION

🇬🇧 Thanks the HERCULE track, Manton propose also a large range of lifting equipment: cranes, jibs, cable carriers...
ASK OUR DOCUMENTATION DEDICATE TO LIFTING!

🇩🇪 Dank des HERCULE Profils bietet auch Manton eine breite Palette von Hebezeug : Leicht Kräne, Schwenkkräne, Kabelwagen...
FRAGEN SIE NACH UNSERE Dokumentation HEBEZEUG GEZIELT!



■ ■ POUTRES ROULANTES ACIER
🇬🇧 STEEL CRANES
🇩🇪 SCHIEBEBÜHNEN STAHL



5.5 M MAX - 1000 KG MAX

■ ■ POUTRES ROULANTES ALUMINIUM
🇬🇧 ALUMINIUM CRANES
🇩🇪 SCHIEBEBÜHNEN ALUMINIUM



6 M MAX - 600 KG MAX

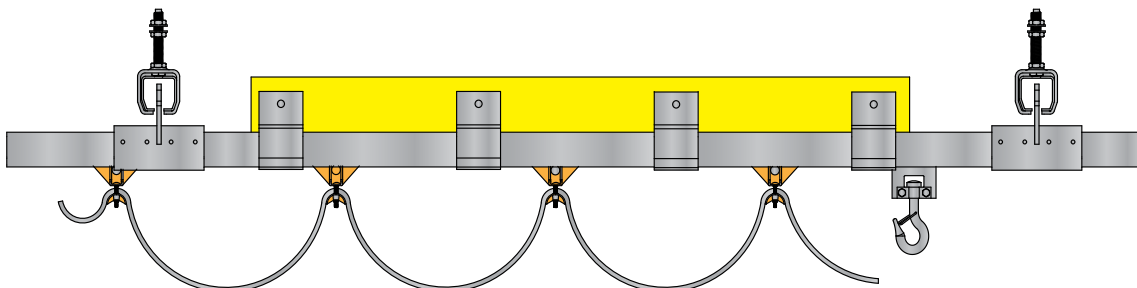



MANTION

MANUTENTION



MANTION S.A.S

7 rue Gay Lussac
FRANCE - 25000 Besançon
Tel. + 33 3 81 50 56 77
Fax. + 33 3 81 53 29 76
E-mail: mantion@mantion.com

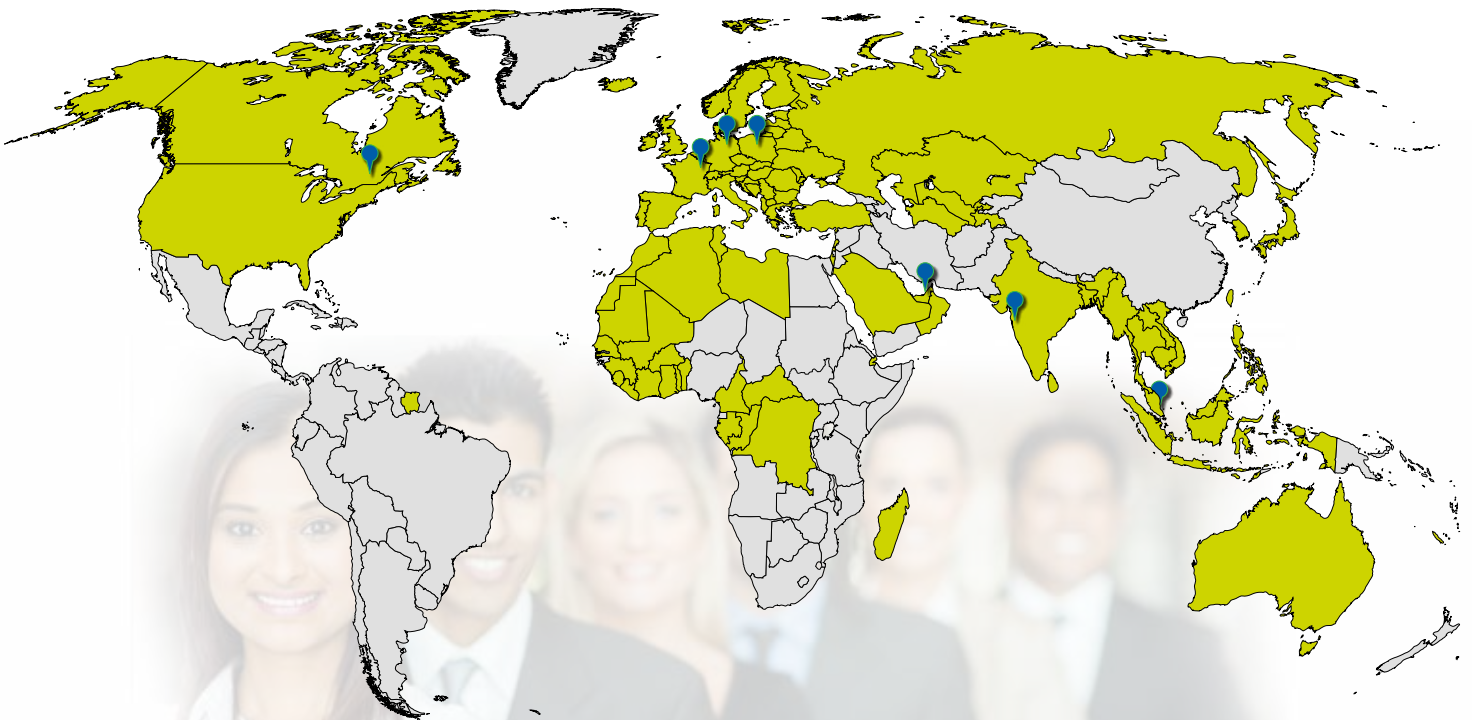

GERMANY **MANTION BAUBESCHLÄGE GMBH**

Dieselstraße 18
D-42579 HEILIGENHAUS
Tél. + 49 2056 58 26 90
Fax. + 49 2056 58 26 99
Email: info@mantion.de
www.mantion.de

POLAND **VALCOMP SP Z.O.O**

ul Boruty 2a
PL-03 769 WARSZAWA
Tél. + 48 22 818 77 22
Fax. + 48 22 818 99 78
Email: biuro@valcomp.com.pl
www.valcomp.com.pl

UNITED ARAB EMIRATES **DUBAI BRANCH OFFICE**

Jafza South, unit no. S101 23 O 032,
Jebel Ali Free Zone, Dubai, UAE
Tél. + 971 56 174 58 44
Email: export@mantion.com
www.mantion.com

INDIA **MUMBAI BRANCH OFFICE**

A-204, Girnar Towers,
G.D. Ambekar Marg,
Opp. P.T. Road Post Office, Kalachowki,
Mumbai 400 033, India
Tél. : + 91 2224 71 81 33
Mobile.: + 91 9818 30 38 78
Email: export@mantion.com
www.mantion.com

SINGAPORE **MANTION SOUTH EAST ASIA**

Pte. Ltd. of 4 Battery Road,
#25-01 Bank of China Building,
Singapore 049908
Mobile. + 65 9147 8440
Email: export@mantion.com
www.mantion.com

CANADA **MANTION CANADA**

760 av. Thomas
Saint Jean sur Richelieu
Québec J2X 5E7
Tél. + 1 450 358 3041
Mobile. + 1 514 770 0861
E-mail: a.lacasse@mantion.com
www.mantion.com